

2805443

Page 1 of 56 07/19/2023 03:46:35 PM Fee \$448 00
Eric Smerad - Gallatin County, MT MISC



After recording, please return to:
PROWELL I, LLC
76 Glasston Road
Big Timber, MT 59011

DECLARATION AND BYLAWS

FOR

NORTH BOWL CONDOMINIUM

DECLARATION

for

NORTH BOWL CONDOMINIUM

INDEX

Certificate of Name 2

Certificate of Floor Plan 3

DECLARATION FOR NORTH BOWL CONDOMINIUM 4

 Definitions 4

 Real Estate 6

 Easement, Common Elements 8

 Ownership and Voting -- Exhibits -- Construction – Use 9

 The Association 14

 Declarant's Right to Change 19

 Amendment 19

 Changes, Repairs and Liens 20

 Insurance 22

 Removal or Partition 27

 Notice to Mortgagees 28

 Remedies 29

 Severability 29

 Interpretation 29

 Miscellaneous 29

CERTIFICATE OF NAME

The undersigned being the duly authorized agent of the Department of Revenue of the State of Montana within the County of Gallatin, herewith executes the following certificate relating to NORTH BOWL CONDOMINIUM, situated as follows:

Lot 5B of the Amended Plat of Lot 5, Annie Subdivision, Phase 2, City of Bozeman, Gallatin County, Montana, according to the official plat thereof on file and of record in the office of the County Clerk and Recorder, Gallatin County, Montana (Plat Reference: J-204-A).

1. That the name NORTH BOWL CONDOMINIUM, is not the same as, similar to or pronounced the same as a word in the name of any other property or subdivision within Gallatin County, except for the word "Condominium", and
2. All taxes and assessments due and payable for the said NORTH BOWL CONDOMINIUM, have been paid to date.

Dated: 6/21/2023



Montana Department of Revenue

CERTIFICATE OF FLOOR PLANS

The undersigned, being a duly registered architect in the State of Montana, herewith certifies the following:

That the floor plans for NORTH BOWL CONDOMINIUM, situated on Lot 5B of the Amended Plat of Lot 5, Annie Subdivision, Phase 2, City of Bozeman, Gallatin County, Montana, according to the official plat thereof on file and of record in the office of the County Clerk and Recorder, Gallatin County, Montana (Plat Reference: J-204-A) as duly filed with this Declaration, fully and accurately depicts the layout, location, unit designation and dimensions of NORTH BOWL CONDOMINIUM as of this date. That the floor plans are an accurate copy of the plans filed with and approved by the officials and officers of the City of Bozeman, Montana having jurisdiction to issue building permits. Such floor plans render hand representation of Unit 1585 as built and Unit 1595 as intended to be built of NORTH BOWL CONDOMINIUM.

Dated: 7.18.23



Nicholas Fulton
Registered Professional Architect
Number: 3051

**DECLARATION FOR
NORTH BOWL CONDOMINIUM**

THIS DECLARATION is hereby made and entered into this 8 day of June, 2023, by PROWELL I, LLC, a Montana limited liability company, of 76 Glasston Road, Big Timber, Montana 59011, hereinafter referred to as "Declarant," whereby the lands and property hereinafter described are submitted to the provisions of Chapter 23, Title 70, MCA, also known as the "Unit Ownership Act" as a condominium.

The property subject to this Declaration shall be known as NORTH BOWL CONDOMINIUM. The current address of NORTH BOWL CONDOMINIUM is 1585 and 1595 25th Avenue, Bozeman, Montana 59718.

I.

DEFINITIONS

Unless the context expressly provides otherwise, the following definitions shall pertain throughout this Declaration and in the interpretation thereof:

1. Aggregate Voting shall mean the entire number of votes or persons present or available to vote in person or by proxy in a particular circumstance.
2. Association or North Bowl Condominium Owners Association, Inc. shall mean all of the Unit Owners acting as a group and in accordance with duly adopted Bylaws and this Declaration.
3. Board or Board of Directors shall mean the Board of Directors of the Association as more particularly defined in the Bylaws.
4. Building shall mean a structure containing a Unit or Units and located on the Property.
5. Bylaws shall mean the Bylaws promulgated by the Association under this Declaration and the Unit Ownership Act.
6. Common Elements shall mean both General Common Elements and Limited Common Elements.
 - a. General Common Elements include all those elements which are for the use of all Unit Owners and guests of Unit Owners of NORTH BOWL CONDOMINIUM. Specifically included are: grounds surrounding the

Buildings, the land on which the Buildings are located, paths, sidewalks and walkways, any portion of the parking areas not specifically allocated to a particular Unit, any irrigation system placed on the property for landscape maintenance, any portions of the Property designated on the Site Plan as common to all Units, electrical, gas, telephone, water and sewer lines and connections serving all of the Units, landscaping, plants and other materials and improvements separate from and outside of the Buildings containing the Units, and other elements necessary for the safety, maintenance and existence of NORTH BOWL CONDOMINIUM in which each Unit Owner shall have his or her designated percentage of interest, as set forth in Paragraph IV below.

b. Limited Common Elements as used in this Declaration shall mean those Common Elements which are reserved for the use of fewer than all of the Owners and guests of Unit Owners of NORTH BOWL CONDOMINIUM, to the exclusion of other such Owners and guests. As to any given Unit Owner or Owners, Limited Common Elements shall mean the Common Elements which are located within or affixed to the Building containing his or her Unit, and which are for the use of the Unit Owners and guests of that Unit in which the elements are located or situated on the real property known as NORTH BOWL CONDOMINIUM.

Specifically included are flues, cables, conduits, public utility lines, water, sewer, electrical, gas, internet or cable television lines that service less than all Units (all such utility pipes and lines are Limited Common Elements where they service less than all Units; where they service all Units, they shall be General Common Elements), stairways, balconies, entrances, stoops, patios, furnaces, decks, driveways, any equipment located outside of a Unit but servicing only that Unit (e.g. HVAC equipment), or other portions of the Property servicing only a particular Unit or less than all of the Units. The percentage of a Unit's interest in a particular Limited Common Element shall be computed by taking the square footage of such Unit and dividing that number by the total square footage of all Units with an interest in such Limited Common Element.

7. Common Expenses shall mean expenses of administration, maintenance, repair or replacement of General Common Elements, expenses agreed upon as common by the Association of all Unit Owners, and expenses declared common by the Unit Ownership Act.
8. Declaration shall mean this document and all parts attached thereto or incorporated by reference.
9. Limited Expenses shall mean the expenses attributable to the maintenance, repair and replacement of Limited Common Elements, and are expenses

only for Owners of Units within the respective Building for which the expenses are accrued.

10. Manager shall mean the manager, the Board of Directors, management corporation, or any other person or group of persons retained or appointed by the Association for the purpose of conducting the day-to-day operations of NORTH BOWL CONDOMINIUM.
11. Property shall mean the real property described in Article II, and all easements, rights and appurtenances belonging thereto, which are herewith submitted to the provisions of the Unit Ownership Act.
12. Unit shall be the separate condominium Units of NORTH BOWL CONDOMINIUM and is a parcel of real property intended for any type of independent use, and with a direct exit to a public street or highway or to a common area or areas leading to a public street or highway; at present, each Building located on the Property constitutes one Unit.
13. Unit Designation shall mean the combination of letters, numbers, or words which identifies the designated Units. Units shall be designated by Unit numbers. Units are designated as follows: Unit 1585 and Unit 1595, subject to the provisions below regarding Division of Units.
14. Unit Owner or Owners shall mean the person or persons owning a fee simple absolute, or one who is a co-owner in any real estate tenancy relationship that is recognized under the laws of the State of Montana, in one or more Units of NORTH BOWL CONDOMINIUM.

II.

REAL ESTATE

Description

The Property which is by this Declaration submitted and subject to the Montana Unit Ownership Act is described as follows:

Lot 5B of the Amended Plat of Lot 5, Annie Subdivision, Phase 2, City of Bozeman, Gallatin County, Montana, according to the official plat thereof on file and of record in the office of the County Clerk and Recorder, Gallatin County, Montana (Plat Reference: J-204-A)

The property which is by this Declaration submitted and subject to the Montana Unit Ownership Act is located within a growth policy area of a first-class municipality and qualifies for a municipal facilities subdivision review exclusion in accord with Section 76-4-

125(1)(d), Montana Code Annotated. The condominium Units of NORTH BOWL CONDOMINIUM shall consist of two (2) separate Units, designated as Unit 1585 and Unit 1595, subject to the provisions below regarding Division of Units. The provisions of this Declaration and the Bylaws shall be construed to be covenants running with the land, and shall include every Unit and shall be binding upon the Unit Owners, their heirs, successors, personal representatives and assigns for as long as this NORTH BOWL CONDOMINIUM Declaration and Bylaws are in effect.

Condominium Units

Each Unit, together with the appurtenant undivided interest in the Common Elements of NORTH BOWL CONDOMINIUM, shall together comprise one condominium unit, shall be inseparable, and may be conveyed, leased, rented, devised or encumbered as a condominium unit. The Units comprising the condominium shall be located in two (2) Buildings with each Building being its own separate Unit, subject to the provisions below regarding Division of Units.

Encroachments

If any portion of the General Common Elements or Limited Common Elements encroaches upon a Unit or Units, a valid easement for the encroachment and for the maintenance of the same, so long as it stands, shall and does exist. If any portion of any Unit encroaches upon the General Common Elements, or Limited Common Elements, a valid easement for the encroachment and for the maintenance of the same, so long as it stands, shall and does exist. Such encroachments and easements shall not be considered or determined to be encumbrances either on the General Common Elements, the Limited Common Elements, or on the Units for the purpose of marketability of title.

Parking Areas

All of the parking areas on the Property are General Common Elements. Use and assignment of parking areas shall be pursuant to regulation of the Association provided that such assignment shall not be arbitrary and shall be fair and non-discriminatory. So long as the Declarant owns a Unit within the Condominium, the Declarant shall have the authority to unilaterally file an amendment to this Declaration assigning parking spaces as Limited Common Elements to particular Units.

Unit Boundaries Before Division

Each of Unit 1585 and Unit 1595 shall include the entire Building constructed on that portion of the Property depicted as such Unit as shown on the Site Plan, including any exterior walls of such Building and anything attached thereto.

Unit Boundaries After Division

After division of Unit 1585 and/or Unit 1595, each divided Unit shall include the part of the Building containing the Unit that lies within the boundaries of the Unit, which boundaries are as follows:

- a. Upper and Lower Boundaries: the upper and lower boundaries of the Unit shall be the following boundaries extended to an intersection with the perimetrical boundaries:
 1. Upper Boundary: the plane of the lowest surfaces of the ceiling joists of the uppermost floor for the Unit.
 2. Lower Boundary: the plane of the highest surface of the floor joists of the lowest floor for the Unit.

- b. Perimetrical Boundaries: the perimetrical boundaries of the Unit shall be the following boundaries extended to an intersection with the upper and lower boundaries;
 1. Exterior Building Walls: the plane of the innermost interior surface of the exterior walls of the Buildings except that such boundary shall be extended so as to include within it all windows and doors in the Unit.
 2. Interior Building Walls: the vertical planes of the centerline of the walls bounding a Unit extended to an intersection with other perimetrical boundaries. Where walls between Units are of varying thicknesses, the plane of the centerline of a boundary wall shall be the median line drawn between the two outermost boundaries of such wall.

III.

EASEMENT, COMMON ELEMENTS

Common Element Easements

A nonexclusive right of ingress, egress and support through the Common Elements is appurtenant to each Unit, and all of the Common Elements are subject to such rights. After division of a Unit as set forth above, a nonexclusive right of ingress, egress and support through the Limited Common Elements within the Building is appurtenant to each Unit.

Easement for Utilities

A non-exclusive easement shall exist through, over and across the General Common Elements and Limited Common Elements (and after division, through over and across the divided Units) for inspection, installation, maintenance, replacement and repair

of utility lines and mechanical equipment for the use of all of the Unit Owners. Such inspection, installation, maintenance, replacement and repair shall only be done under the direction and approval and with the authority of the Association unless an emergency exists in which event any action, including entry into a Unit, may reasonably be taken which is justified under the circumstances to minimize damage which would otherwise occur as a consequence of such emergency.

Interior Remodeling

Each Unit Owner shall have the exclusive right to paint, repaint, tile, wax, paper, panel, carpet, brick or otherwise maintain, refinish and decorate the inner surfaces of the walls, ceilings, floors, windows and doors bounding his or her own Unit, and the interior thereof, so long as such Owner does not affect the structural integrity of the Building in which his or her Unit is located.

IV.

OWNERSHIP AND VOTING - EXHIBITS - CONSTRUCTION - USE

Percentage of Interest

Each Unit Owner shall be entitled to the exclusive ownership, use and possession of his or her Unit. Additionally, each Unit Owner shall have a percentage of undivided interest in the General Common Elements of NORTH BOWL CONDOMINIUM. Such percentage represents his or her ownership interest in the General Common Elements, his or her voting interest, and his or her liability for Common Expenses. Subject to the provisions below regarding Division of Units, the percentage of interest in the General Common Elements for the respective Owners shall be computed by taking the approved number of housing units that are permitted for each Unit by the City of Bozeman at the date of filing this Declaration and dividing it by the total number of housing units that are permitted for NORTH BOWL CONDOMINIUM by the City of Bozeman. Such percentage of interest owned by each of the Units in NORTH BOWL CONDOMINIUM shall be according to the percentages set forth below:

UNIT NO.	PERMITTED HOUSING UNITS	PERCENTAGE OF INTEREST IN GENERAL COMMON ELEMENTS
1585	7	28%
1595	18	72%
TOTAL	25	100%

Floor Plans and Exhibits

NORTH BOWL CONDOMINIUM consists of two (2) Buildings and the real property described in Paragraph II above which contains a total of two (2) separate NORTH BOWL CONDOMINIUM Units as shown on the site plan and floor plans, subject to the provisions below regarding Division of Units. Phase I of the Condominium shall consist of Unit 1585 and Phase II of the Condominium shall consist of Unit 1595.

For identification and descriptive purposes the following Exhibits are attached and by reference hereto incorporated into and made a part of this Declaration:

Exhibit A: showing the site plan of NORTH BOWL CONDOMINIUM and the location of the Buildings containing NORTH BOWL CONDOMINIUM Units on the Property.

Exhibit B: showing the proposed floor plans for each of the Units of NORTH BOWL CONDOMINIUM, the proposed square footage of each and the designation for each Unit. The floor plans attached hereto are subject to change upon completion of construction for Unit 1595 as more specifically described below.

Supplemental Declaration

Construction of Unit 1595 in Phase II is not completed as of the date of recording this Declaration. Within thirty (30) days upon completion of the construction of Unit 1595 or from the date of the first occupancy of the Unit, whichever occurs first, the Unit Owner shall file a supplement to this Declaration as to that Unit only and setting forth the following information:

- a. final floor plans as to such Unit;
- b. a certificate executed by an architect, land surveyor, or engineer certifying that the final floor plans fully and accurately depict the layout of the Unit and the improvements in the Building as constructed and the date that the construction of such Unit and Building was completed; and
- c. a description of the Building and the materials of which it is constructed;

The Owner of Unit 1595 need not obtain the consent of any other Unit owner when recording a Supplemental Declaration as to Unit 1595, however, the Supplemental Declaration may not alter the boundaries of any other Unit, the General Common Elements, or make any other substantive change to this Declaration without a duly executed amendment to this Declaration as herein provided.

Stormwater Water Maintenance Plan

Attached hereto as Exhibit "C" is the Stormwater Maintenance Plan that is binding upon the Condominium. The Association shall follow and adhere to such plan.

Construction Materials

The proposed principal materials of construction of the Units are concrete for the foundations, footings, and slabs, wood and wood products for the framing, structural and finish work, sheet rock, composite board, wood products, and plywood for the interior, carpet, wood, wood products, vinyl, or tile for the floors, metal, fiber cement and wood-product siding for exterior wall surfaces, and asphalt shingles for the roof of the Buildings.

Division of Units

Unit 1585 may be divided into seven (7) condominium units by its Owner, and Unit 1595 may be divided into eighteen (18) condominium units by its Owner. At such time as the Owner of Unit 1585 and/or the Owner of Unit 1595 wishes to divide its respective Unit and add such additional Units to this condominium regime, said Unit Owner shall record for its Unit, in the office of the Clerk and Recorder of Gallatin County, Montana, a Supplemental Declaration containing:

- a. An updated site plan showing the location of the new Units added to the condominium regime;
- b. Floor plans showing the new Units contained within the divided Unit (in the event Unit 1585 is divided, the new Units shall be known as 1585A, 1585B, 1585C, 1585D, 1585E, 1585F, 1585G; and in the event Unit 1595 is divided, the new Units shall be known as 1595A, 1595B, 1595C, 1595D, 1595E, 1595F, 1595G, 1595H, 1595I, 1595J, 1595K, 1595L, 1595M, 1595N, 1595O, 1595P, 1595Q, and 1595R);
- c. A schedule of the percentage of undivided ownership of the specific Units to be added to the condominium regime in the General Common Elements. Each divided Unit's ownership interest shall be four percent (4%);
- d. To be and remain in compliance with the provisions of Section 70-23-306, MCA, at the time of the filing of such Supplemental Declarations, a revised site plan and floor plans together with a certificate executed by an architect, land surveyor, or engineer shall be prepared and recorded, certifying and showing that the said floor plans fully and accurately depict the layout of the Units in the floors of the Buildings and that construction of each such additional new Building has been completed.

At the time the Owners of such Units 1585 and/or 1595 elect to file such Supplemental Declarations to this Declaration, all then existing condominium Unit Owners hereby covenant and agree that they will, upon request, join in the execution of such

amendment papers agreeing, consenting and joining in such Supplemental Declaration, and further agreeing to reduce their percentage of ownership interest in the General Common Elements.

The Owner of the Unit being divided need not obtain the consent of any other Unit Owner when recording a Supplemental Declaration as to his or her Unit, however, the Supplemental Declaration may not alter the boundaries of any other Unit, the General Common Elements, or make any other substantive change to this Declaration without a duly executed amendment to this Declaration as herein provided.

The within agreement shall be a covenant running with the land, and shall be binding upon the Owners of the then existing Units, who upon acquiring title to such Unit, by this covenant agree and consent to the filing of such Supplemental Declaration and join in the same, and by this covenant agree and consent to the appointment of the Unit Owner filing the Supplemental Declaration as its attorney-in-fact, coupled with an interest, so that such Unit Owner may in its discretion simply file the Supplemental Declaration on its own initiative, having been herein given the power and authority to make such amendment for and on behalf of all subsequent condominium Owners in NORTH BOWL CONDOMINIUM.

Except as otherwise specifically provided in this Declaration or in such Supplemental Declarations, all of the provisions, terms and definitions herein contained shall, upon recording of the same, be deemed expanded to include the additional Units.

Use

The use of all of the Units in NORTH BOWL CONDOMINIUM shall be for residential purposes only and there shall be no commercial use whatsoever, except that nothing shall prohibit a Unit Owner from leasing or renting his or her Unit, or any portion thereof, to third persons or holding it out for lease or rental, or entering into an Agreement or contract with others for the lease or rental of his or her Unit for residential use. The use of the General Common Elements shall be for the recreation and enjoyment of the Unit Owners, their guests, tenants, lessees and invitees. The Units and Common Elements shall be limited as follows:

- a. There shall be no obstruction of the Common Elements, nor shall anything be stored in or on the General Common Elements without the prior written consent of the Association. Each Owner shall be obligated to maintain and keep in good order and repair the interior and exterior of his or her own Unit and Building.
- b. Nothing shall be done or kept in any Unit or in the Common Elements which will increase the rate of insurance on the General Common Elements, without the prior written consent of the Association. No Owner shall permit anything to be done or kept in his or her Unit or in the Common Elements which will result in the cancellation of insurance on the Common Elements, or which would be in violation of any law. No waste will be permitted on the Common Elements.

c. No nuisances shall be allowed upon the Property nor shall any use or practice be allowed which is a source of annoyance to Unit Owners or which interferes with the peaceful possession and proper use of the property by its residents. No offensive or unlawful use shall be made of the Property nor any part thereof, and all valid laws, zoning ordinances and regulations of all governmental bodies having jurisdiction thereof shall be observed.

d. Unit Owners shall not cause or permit anything to be hung or displayed on the outside of windows or placed on the outside walls of a Building, and no sign, awning, canopy, satellite dish, radio or television antenna shall be affixed to or placed upon the exterior walls or roof of any part thereof, without the prior written consent of the Association. The size, location and placement of all signs must be approved by the Board before installation. All signs must be in conformity with any zoning and sign ordinance then in effect. Seasonal decorations that are promptly removed after the season and reasonable name plates or identification signs for individual Units may be allowed.

e. No animals of any kind shall be raised, bred, or kept in any individual dwelling unit located within a Unit, except that no more than a total of three (3) household pets per household may be kept subject to rules and regulations from time to time adopted or amended by the Association. All dogs must be kept on a leash while on the Property. Additionally, Unit Owners, their tenants, and any guests, shall be responsible for the immediate clean-up of any pet waste and the repair of any damage caused by pets to any of the General Common Elements or Limited Common Elements. Any pet which bites another animal or a human upon the premises shall be immediately and permanently removed unless it can be shown by clear and convincing evidence, as determined by the Board, that the animal was unreasonably provoked into such action. For purposes of the foregoing sentence, any animal which is restrained in some reasonable fashion but is approached by another animal or human shall be presumed to be the non-aggressor. Failure to timely remove the pet(s) can result in a fine not to exceed \$20.00 per day for each day the pet remains on the Property or in the Unit, which fine shall become part of the assessments for that Unit. Failure to immediately pick up after a Unit Owner's animal or an animal belonging to a tenant of the Unit on the common area will result in a \$50.00 fine for each offense, which shall also become a part of the assessment for Unit, regardless of whether the offending animal is owned by the Unit Owner or by a tenant of the Unit or any portion thereof. Failure of an Owner to adhere to pet regulations and requirements shall be grounds for the Association and other Unit Owners to maintain a nuisance action to remove the offending pet(s). The Association shall have the authority to ban certain breeds of dogs or individual dogs from NORTH BOWL CONDOMINIUM, provided that such actions are based upon objective criteria related to aggressive tendencies of the breed or individual dogs. In the event that an Owner leases his or her Unit to a person who has pets, the Owner of the Unit shall be responsible for the enforcement of the pet restrictions and rules, and any fines imposed shall be a charge against the Unit, for which the

Association may obtain satisfaction in the same manner as if the Unit Owner failed to pay an assessment imposed against the Unit. The Association shall have the right to file a lien against the Unit and shall have the right to foreclose said lien in the same manner as provided herein.

f. Nothing shall be altered or constructed in or removed from the Common Elements, and no easements, liens or encumbrances placed on the Common Elements, except upon the written consent of sixty percent (60%) of the aggregate ownership interest of the Unit Owners affected by such action.

g. All garbage shall be kept in appropriate containers. No junk, garbage, trash, equipment, parts, metals, lumber, debris, or other waste shall be allowed on the driveways or any Common Elements unless permitted by the Association.

h. Campers, trailers, boats and other recreational vehicles may only be brought onto the Property or onto any street bordering the Property for loading and unloading for immediate use. No inoperable vehicles, and no campers, boats, recreational vehicles, or trailers, shall be left parked in the condominium parking areas or on driveways or garage parking pads or on any street bordering the condominium Property for more than 24 hours at one time. Repeated parking of such vehicles or trailers is also prohibited. No one may reside in any recreational vehicles, trailers, or motor homes upon the Property. Violators of this paragraph are subject to towing and fines levied by the Board in the Board's discretion.

Exclusive Ownership

Each Owner or Owners shall be entitled to exclusive ownership and possession of their Unit. Such Owners may use the General Common Elements and Limited Common Elements in accordance with the purposes for which they are intended and this Declaration and as they may otherwise agree between themselves, so long as they do not hinder or encroach upon the lawful rights of other Unit Owners. The right of a Unit Owner to sell, transfer, or otherwise convey his or her Unit in the NORTH BOWL CONDOMINIUM shall not be restricted by a right of first refusal or similar restriction in the Declaration and Bylaws (or any amendment thereto).

V.

THE ASSOCIATION

Membership

Any Owner of a Unit in NORTH BOWL CONDOMINIUM shall automatically, upon becoming the Owner of said Unit, be a member of the NORTH BOWL CONDOMINIUM OWNERS ASSOCIATION, INC., a Montana nonprofit corporation, hereinafter referred to as the Association, and shall remain a member of said Association until such time as his

or her membership in said Association shall automatically cease. The membership shall be limited to Unit Owners as defined in this Declaration.

Function

It shall be the function of the Association to:

- a. Adopt Bylaws for the governance of the Association.
- b. Make provisions for the general management and/or repairs and maintenance of NORTH BOWL CONDOMINIUM.
- c. Levy fines and assessments as provided for in the Declaration, Bylaws and Unit Ownership Act.
- d. Adopt and implement a policy for the affairs of the Association.
- e. Enter into contracts or hire personnel for the management of the affairs of the Association and the maintenance and repair of the common areas.
- f. Be responsible for the perpetual maintenance of the landscaping, common open space, parking lots, and driving lanes.

Voting

On all matters, unless excluded by this Declaration, to be decided by the Association, each Unit Owner shall have a vote equal to his or her percentage of interest in the General Common Elements. Multiple owners of a single condominium Unit shall collectively have such voting interest. In the event that Unit Owners of the same Unit cannot agree as to how to vote that Unit's interest, said Unit's vote shall be suspended for that particular matter.

An owner of a condominium Unit, upon becoming an owner, shall be a member of the Association and remain a member for the period of his or her Unit ownership. Except as otherwise provided in the Unit Ownership Act, this Declaration or the Bylaws, a majority of the Unit ownership percentage present at any meeting or by proxy shall be sufficient to act on matters brought before the Unit Owners. Meetings of the Unit Owners shall only be conducted when a quorum is present, as defined in the Association Bylaws.

Failure to Comply

Each Owner shall comply strictly with the provisions of this Declaration, the Bylaws, and the rules, regulations, decisions and resolutions of the Association adopted pursuant thereto as the same may be lawfully amended from time to time. Failure to comply with any of the same shall be grounds for an action to recover sums due, for damages or

injunctive relief or both, and for reimbursement of all costs, including attorney fees incurred in connection therewith, which action shall be maintainable by the Manager in the name of the Association, on behalf of the Owner, or in the proper case, by an aggrieved Owner. Each Unit Owner shall also comply with any applicable subdivision covenants, rules and regulations for the subdivision in which the NORTH BOWL CONDOMINIUM is located.

Fines

The Association, acting through the Board or the Manager, shall have the authority to levy fines against Units for any violation of the covenants set forth herein or for any violation of the rules and regulations duly adopted by the Board. Violations caused by a tenant shall be assessed against the occupied Unit and shall be the responsibility of the Unit Owner. For each violation, the Unit Owner may be fined according to the following fine schedule:

First Offense:	\$50.00
Second Offense:	\$75.00
Third Offense and More:	\$150.00

The fine schedule may be amended by the Board at any duly called meeting provided it is thereafter approved by at least sixty percent (60%) of the aggregate Unit ownership interest at any regular or special meeting of the Association. All fines shall be considered final and shall be considered an assessment and a lien against the Unit unless the Unit Owner makes a written appeal to the Board within five (5) business days of receiving the fine and the Board subsequently overturns such fine. The Board shall have thirty (30) days to meet and render its decision regarding the fine, which decision shall be final. All fines may be collected by the Association in the same manner as an assessment as set forth herein. All fines not paid within thirty (30) days shall accrue interest at the then maximum current legal rate of interest per annum on the amount of the fine from the due date thereof.

Payment of Assessments

All assessments shall be due ten (10) days from the date of mailing such assessment following the meeting at which time assessments are levied by the Association, and may be payable in one annual payment, or in quarterly or monthly installments, as determined by the Board. The amount of the Common Expenses assessed against each Unit, and the amount of Limited Expenses assessed against each Unit shall be the personal and individual debt of the Owner or Owners thereof. No Owner may exempt himself or herself from liability for this contribution toward the Common Expenses and the Limited Expenses by waiver of the use of enjoyment of any of the General Common Elements or Limited Common Elements or by abandonment of his or her Unit. All assessments which are not paid within thirty (30) days from the date they are due and payable become delinquent and are subject to interest and penalty charges.

The Association or Manager shall have the responsibility of taking prompt action to collect any unpaid assessment which becomes delinquent. In the event of delinquency in the payment of the assessment, the Unit Owner shall be obligated to pay interest at the then maximum current legal rate of interest per annum on the amount of the assessment from the due date thereof and any late payment charges assessed, together with all expenses, including attorney fees incurred, as are provided in the Bylaws of the Association. Suit to recover a money judgment for unpaid Common Expenses and Limited Expenses may be maintainable without foreclosing or waiving the lien securing the same.

Levying Assessments - When Made - Purposes

The Association of Unit Owners shall levy assessments upon the Unit Owners in the following manner and for the following reasons:

- a. Assessments shall be made as a part of the regular business of the Board of Directors of the Association at any regular or special meeting thereof as provided in the Bylaws of the Association. Notice of the proposed assessment, amount thereof, and the purpose for which it is made whether regular or special, including an annual budget for expenditures and operation, shall be served on each Unit Owner affected by delivering a copy of the same to the Unit Owner personally or by mailing a copy of the notice to the Unit Owner at his or her address of record at least ten (10) days prior to the date for such meeting. The Board of Directors shall approve the budget and the amount of assessments.
- b. Assessments shall be made for the repair, replacement, general maintenance, management and administration of Common Elements, fees, costs and expenses of the manager, insurance, taxes for common areas if any, and as more particularly provided in the Unit Ownership Act (Section 70-23-101, et. seq., MCA), sidewalks, driveways, weed control, and any other matters that fall within the Common Elements of the condominium. In addition, the Association shall be responsible for all special improvement district (SIDs) applicable to the NORTH BOWL CONDOMINIUM, including, but not limited to, lighting districts, street maintenance, tree maintenance or any other properly created SID, and assessments shall be levied for the same. Assessments shall be based upon and computed by using the percentage of interest that each Unit Owner has in the General Common Elements.
- c. Assessments may also be made for the payment of Limited Expenses for Limited Common Elements such that the Unit Owners are chargeable only for the expenses relating to their respective Units or Buildings. Unit Owners shall share in the payment for Limited Expenses for the repair, maintenance and replacement of Limited Common Elements of their respective Units in accordance with the percentage the Unit or Units have in the Limited Common Elements for which the assessment is being made. If only one Unit is associated with the Limited Common

Elements involved, then the entire cost of such repair, maintenance or replacement shall be borne by that Unit.

d. Assessments may also be made for any purpose contemplated by this Declaration and for any purpose set out in the Montana Unit Ownership Act.

e. Common expenses and profits, if any, of the condominium shall be distributed among and charged to, the Unit Owners according to the percentage of undivided interest of each in the Common Elements.

f. In a voluntary conveyance of a Unit, the Grantee of the Unit shall be jointly and severally liable with the Grantor for all unpaid assessments by the Association against the latter for his or her share of the Common Expenses up to the time of the grant or conveyance, without prejudice to the Grantee's right to recover from the Grantor the amounts paid by the Grantee therefor. However, any such Grantee shall be entitled to a statement from the Manager or Board of Directors of the Association, as the case may be, setting forth the amount of said unpaid assessments against the Grantor due the Association and such Grantee shall not be liable for, nor shall the Unit conveyed be subject to a lien for, any unpaid assessments made by the Association against the Grantor in excess of the amount therein set forth.

g. Any lien of the Association for Common Expense charges and assessments becoming payable on or after the date of recordation of the first mortgage or deed of trust, shall be subordinate to the first mortgage or deed of trust on the Unit. Such a lien for Common Expense charges and assessments shall not be affected by any sale or transfer of a Unit, except that a sale or transfer of a Unit pursuant to a foreclosure of a first mortgage or deed of trust shall extinguish a subordinate lien for common expense charges and assessments which became payable prior to such sale or transfer. Any such sale or transfer pursuant to a foreclosure shall not relieve the purchaser or transferee of a Unit from liability for, nor the Unit so sold or transferred from the lien of, any common expense charges thereafter becoming due.

h. Prior to the initial sales of Units within the Condominium, an initial assessment amount, including a capital contribution (reserves), may be established for each Unit. Said assessment amount shall be paid to the Association at the close of each Unit or upon the transfer of the deed for each Unit. The Association shall establish a reserve account for repair and replacement of Common Elements as needed to keep such in good condition and repair. Any reserve account established under this section shall be funded by separate reserve assessments against the Units in such amount as the Board may approve as a part of the annual Association budget. Any reserve account shall be established in the name of the Association. The Association shall be responsible for administering the account. Assessments

paid into the reserve account are the property of the Association and are not refundable to sellers or Unit Owners.

VI.

DECLARANT'S RIGHT TO CHANGE

The Declarant reserves the right to change the interior design and arrangement of all Units, and alter the boundaries between Units, so long as the Declarant owns the Unit so altered. No such change shall increase the number of Units or alter the boundary of the General Common Elements without an amendment of this Declaration.

Until ninety percent (90%) of the Units (in all phases) have been sold, Declarant: (i) reserves the right to establish easements, reservations, exceptions and exclusions consistent with the condominium ownership project; and (ii) reserves the right to exercise the rights, duties and functions of the Board of Directors of the Association.

During the period of development and sale of the remaining condominium Units, the monthly assessment for Common Expenses for Units owned by the Declarant shall be based upon the estimate of the actual cost thereof, excluding therefrom any estimated amount for contingencies, reserves or sinking funds, and Declarant shall pay its pro rata share thereof only for those condominium Units which have been completed. During the period when fewer than all of the Units have been erected, the Common Expenses shall be allocated among the Owners of such existing Units.

VII.

AMENDMENT

This Declaration may be amended at any regular or special meeting of the Association of Unit Owners provided such amendment receives the favorable vote of at least seventy-five percent (75%) of the aggregate Unit ownership interest. If so approved, it shall be the responsibility of the Association to file the amendment with the Clerk and Recorder's Office of Gallatin County, Montana.

An amendment may be adopted at any time without a meeting if it is approved in writing by the notarized signatures of one hundred percent (100%) of the Unit Owners.

Notwithstanding the procedure set forth above, the Declarant may amend this Declaration, or any other project document, prior to the conveyance of a Unit or interest thereof. Notwithstanding the procedures set forth above, Declarant reserves the right at any time, on behalf of itself and on behalf of the Association, to amend this Declaration and the Bylaws without approval of any Unit Owner for the purpose of correcting survey or other errors and for any other purpose unless the amendment would materially alter or change

the rights of a Unit Owner or mortgagee, in which event consent shall be required as provided in this article.

Notwithstanding the procedure set forth above, the Declarant may amend this Declaration, or any other project document, for purposes of expanding the condominium as set forth in the expansion provisions above and may also amend this Declaration, or any other project document, prior to any sale or lease of a Unit or interest thereof. Notwithstanding the procedure set forth above, the Owner of Unit 1585 and/or 1595 may amend this Declaration or any other project document pursuant to the provisions above regarding Division of Units.

Any right granted or reserved to Declarant may not be changed by an amendment unless consented to, in writing, by the Declarant. Declarant reserves the right to assign any and all of its rights reserved or granted herein.

VIII.

CHANGES, REPAIRS AND LIENS

Alterations by Unit Owners Association

The interior plan of a Unit may be changed by the Owner. The boundaries between Units may be changed only by the Owners of the Units affected. No change in the boundaries of Units shall encroach upon the boundaries of the Common Elements.

After a Unit 1585 and/or Unit 1595 is divided pursuant to the Division of Units provisions set forth above, the following provisions in this paragraph regarding alterations of the interior of Units shall apply to such Units. Boundary walls must be equal in quality of design and construction to the existing boundary walls. A change in the boundaries between Units shall be set forth in an amendment to this Declaration. In addition to compliance with the provisions of Article VII above, such amendment must further set forth and contain plans for the Units concerned showing the Units after the change in boundaries, which plans shall be drawn by an architect, surveyor or engineer licensed to practice in Montana, and attached to the amendment as exhibits, together with the certificate of architect, surveyor or engineer required by the Unit Ownership Act. Such an amendment shall be signed and acknowledged by the Owners of the Units concerned, as well as those Owners with an interest in any Common Element affected. The amendment shall also be approved by the Board of Directors of the Association, and signed and acknowledged by all lienors and mortgagees of the Units concerned.

Maintenance by Unit Owners

Each Unit Owner shall maintain and keep in repair the interior and exterior of his or her own Unit, including the fixtures thereof. All fixtures and equipment installed in the Unit, commencing at a point where the utilities enter the Unit and/or Building, shall be

maintained and kept in repair by the Owner thereof. An Owner shall do no act nor any work that will impair the structural soundness or integrity of the Buildings or impair any easement.

Each Unit Owner shall also keep any balconies, patios, entrances or deck areas appurtenant to his or her Unit in a clean and sanitary condition. The right of the each Owner to repair, alter, and remodel is coupled with the obligation to replace any finishing or other materials removed with similar type or kinds of materials. All glass replacement shall be with similar quality, shade and design. No act or alteration, repairing or remodeling by any Unit Owner shall impair in any way the integrity of the adjoining Units or the integrity of Limited Common Elements or General Common Elements.

Exterior Alterations after Division of Units

After a division of Unit 1585 and/or Unit 1595, no Owner may change, alter or remodel the exterior of his or her Unit without the prior written approval of the Association.

Liens for Alterations

Labor performed and materials furnished and incorporated into a Unit with the consent of or at the request of the Unit Owner, his or her agent, his or her contractor or subcontractor shall be the basis for the filing of a lien against the Unit of the Unit Owner consenting to or requesting the same. Each Unit Owner shall indemnify and hold harmless each of the other Unit Owners from and against all liability arising from the claim of any lien against the Unit or any other Owner or against the general or Limited Common Elements for construction performed or for labor, materials, services or other products incorporated in the Owner's Unit at such Owner's request.

Liens and Foreclosure

All sums assessed but unpaid for the share of Common Expenses and Limited Expenses chargeable to any Unit shall constitute a lien on such Unit superior to all other liens and encumbrances, except only for tax and special assessment liens on the Unit in favor of any assessing authority, and all sums unpaid on a first mortgage, a first deed of trust, or contract for deed, of record. To evidence such lien, the Association shall prepare a written notice of lien assessment setting forth the amount of such unpaid indebtedness, the amount of accrued interest and late charges thereon, the name of the Unit Owner, and a description of the Unit. Such notice shall be signed and verified by one of the officers of the Association or by the Manager, or his or her authorized agent, and shall be recorded in the office of the Clerk and Recorder of Gallatin County, Montana. Such lien shall attach from the date of recording such notice. Such lien may be enforced by the foreclosure of the defaulting Owner's Unit by the Association as provided in the Unit Ownership Act in like manner as foreclosure of a mortgage on real property. In any foreclosure, the Unit Owner shall be required to pay a reasonable rental for the Unit, if so provided in the Bylaws, and the plaintiff in such foreclosure action shall be entitled to the appointment of a receiver to collect the same. Suit to recover a money judgment for unpaid Common Expenses and

Limited Expenses shall be maintainable without foreclosure or waiving the lien securing the same. In any such proceeding the Owner shall be required to pay the costs, expenses and attorney's fees incurred in filing a lien, and in the event of foreclosure proceedings, additional costs, expenses and attorney's fees incurred.

Bidding at Foreclosure

The Association shall have the power to bid on the Unit at a foreclosure or other legal sale, and to acquire and hold, lease, mortgage and vote the votes appurtenant to, convey or otherwise deal with the same. Any lienholder holding a lien on the Unit may pay, but shall not be required to pay, any unpaid General Common Expenses or Limited Expenses payable with respect to any such Unit, and upon such payment such lienholder shall have a lien on said Unit for the amounts paid of the same priority as the lien of his or her encumbrance without the necessity of having to file a notice or claim of such lien.

IX.

INSURANCE

Purchase

All insurance policies upon NORTH BOWL CONDOMINIUM property shall be purchased by the Association and shall be issued by an insurance company authorized to do business in Montana.

- a. Named Insured: The named insured shall be the Association individually and as agent for the Unit Owners without naming them. Such policies shall provide that payments for losses thereunder by the insurer shall be paid to the insurance Trustee hereinafter designated, and all policies and endorsements thereon shall be deposited with the insurance Trustee. Unit Owners may obtain insurance coverage, at their own expense, upon their own personal property and for their personal liability and living expense.
- b. Copies to Mortgagees: One copy of each insurance policy and of all endorsements thereon shall be furnished by the Association to each mortgagee of a Unit Owner on request.

Coverage

- a. Casualty: All Buildings and improvements upon the land shall be insured in an amount equal to the full insurable replacement value, and all personal property included in the Common Elements shall be fully insured, with all such insurance to be based on current replacement value, as determined annually by the Board of Directors, but subject to such deductible clauses as are required in order to obtain coverage at reasonable costs. The insurance policy shall afford, as a minimum, protection against the following:

- (1) loss or damage by fire and other perils normally covered by the standard extended coverage endorsement;
- (2) in the event the condominium contains a steam boiler, loss or damage resulting from steam boiler equipment accidents in an amount not less than \$50,000 per accident per location (or such greater amount as deemed prudent based on the nature of the Property);
- (3) all other perils which are customarily covered with respect to condominiums similar in construction, location and use, including all perils normally covered by the standard "all-risk" endorsement, where such is available.

If available and commonly required by prudent institutional mortgage investors in Gallatin County, Montana, such policies shall also include an "Agreed Amount Endorsement" and an "Inflation Guard Endorsement".

Insurance coverage shall afford protection against:

- (1) Loss or damage by fire and other hazards covered by a standard extended coverage endorsement; and
- (2) Such other risks as from time to time shall be customarily covered with respect to Buildings similar in construction, location and use as the Building on the land, including, but not limited to, vandalism and malicious mischief.
- (3) Errors or Omissions Insurance for the Directors, Officers and Managers, if the Association so desires, in amounts to be determined by the Board.

The policies shall state whether air handling or service equipment, interior fixtures and carpets are included within the coverage in order that Unit Owners may insure themselves if the items are not insured by the Association.

b. **Public Liability:** The Association shall maintain comprehensive general liability insurance coverage covering all of the Common Elements, commercial space owned and leased by the Association, and public ways of the condominium project. Coverage limits shall be in amounts generally required by private institutional mortgage investors for projects similar in construction, location, and use. However, such coverage shall be for at least \$1,000,000 for bodily injury, including deaths of persons and property damage arising out of a single occurrence. Coverage under this policy shall include, without limitation, legal liability of the insureds for property damage, bodily injuries and deaths of persons in connection with the operation, maintenance or use of the Common Elements, and legal liability arising out of lawsuits related to employment contracts of the Association. Such policies must provide that they may not be cancelled or substantially modified, by

any party, without at least 10 days' prior written notice to the Association and to each holder of a first mortgage on any Unit in the Condominium which is listed as a scheduled holder of a first mortgage in the insurance policy.

c. Other Insurance: Such other insurance as the Board of Directors of the Association shall determine from time to time to be desirable and as may be required by Federal and State laws.

d. For all insurance policies, the Association shall only use generally acceptable insurance carriers

Premiums

Premiums for insurance policies purchased by the Association shall be paid by the Association as a Common Expense, except that the amount of increase in the premium occasioned by use, misuse, occupancy or abandonment of a Unit or its appurtenances or of the Common Elements by a Unit Owner shall be assessed against the Owner. Not less than ten (10) days prior to the date when a premium is due, evidence of such payment shall be furnished by the Association to each mortgagee listed in the roster of mortgagees.

Insurance Trustee

All insurance policies purchased by the Association shall be for the benefit of the Association and the Unit Owners and their mortgagees as their interests may appear, and shall provide that all proceeds covering property losses shall be paid to such bank in Montana with trust powers as may be designated as insurance trustee by the Board of Directors of the Association, which trustee is herein referred to as the insurance trustee. The insurance trustee shall not be liable for payment of premiums, nor for the renewal or the sufficiency of policies, nor for the failure to collect any insurance proceeds. The duty of the insurance trustee shall be to receive such proceeds as are paid and hold the same in trust for the purposes elsewhere stated in this instrument and for the benefit of the Unit Owners, and their mortgagees in the following shares, but which shares need not be set forth on the records of the insurance trustee:

a. Unit Owners - An undivided share for each Unit Owner, such share being the same as the undivided share in the Common Elements appurtenant to his or her Unit.

b. Mortgagees - In the event a mortgagee endorsement has been issued as to a Unit, the share of the Unit Owner shall be held in trust for the mortgagee and the Unit Owner as their interests may appear; provided, however, that no mortgagee shall have any right to determine or participate in the determination as to whether or not any damaged property shall be reconstructed or repaired, and no mortgagee shall have any right to apply or have applied to the reduction of a mortgage debt any

insurance proceeds except distributions thereof made to the Unit Owner and mortgagee pursuant to the provision of this Declaration.

Distribution of Proceeds

Proceeds of insurance policies received by the insurance trustee shall be distributed to or for the benefit of the beneficial Owners in the following manner:

- a. Miscellaneous: Expenses of administration, the insurance trustee, and construction or remodeling supervision shall be considered as part of the cost of construction, replacement or repair.
- b. Reconstruction or Repair - If the damage for which the proceeds are paid is to be repaired or reconstructed by the Association, the remaining proceeds shall be paid to defray the cost thereof as elsewhere provided. Any proceeds remaining after defraying such costs shall be distributed to the beneficial Owners, remittances to Unit Owners and their mortgagees being payable jointly to them.
- c. Failure to Reconstruct or Repair - If it is determined in the manner elsewhere provided that the damage for which the proceeds are paid shall not be reconstructed or repaired, the remaining proceeds shall be distributed to the beneficial owners, remittances to Unit Owners and their mortgagees being payable jointly to them.
- d. Certificate - In making distribution to Unit Owners and their mortgagees, the insurance trustee may rely upon a certificate from the Association made by its representative or Manager as to the names of the Unit Owners and their respective shares of the distribution.

Association as Agent

The Association is irrevocably appointed agent for each Unit Owner and for each Owner of a mortgage or other lien upon a Unit and for each Owner of any other interest in the condominium property to adjust all claims arising under insurance policies purchased by the Association and to execute and deliver releases upon the payment of claims.

Benefit to Mortgagees

Certain provisions in this paragraph entitled "Insurance" are for the benefit of mortgagees or trust indenture beneficiaries of condominium parcels, and all such provisions are covenants for the benefit of any mortgagee of a Unit and may be enforced by such mortgagee or beneficiary.

Reconstruction

A. Repair After Casualty

If any part of the condominium property shall be damaged by casualty, whether or not it shall be reconstructed or repaired shall be determined in the following manner:

1. Lesser Damage - If a Unit or Units are found by the Board of Directors of the Association to be tenantable after the casualty, the damaged property shall be repaired.
2. Greater Damage - If a Unit or Units are found by the Board of Directors to be not tenantable after the casualty, the damaged property shall be reconstructed or rebuilt.
3. Certificate - The insurance trustee may rely upon a certificate of the Association made by its president and secretary to determine whether or not the damaged property is to be reconstructed or repaired.

B. Plans and Specifications

Any reconstruction or repair must be substantially in accordance with the plans for specifications and the original improvements, or if not, then according to plans and specifications approved by: (1) the Board of Directors; and (2) more than seventy-five percent (75%) of the aggregate unit voting interest, including the Owners of all Units the plans for which are to be altered. Any such reconstruction not in accordance with the original plans and specifications must be set forth in an amendment to the Declaration, which amendment shall be filed of record in accordance with the provisions of such amended filing, more particularly set forth in Article VII and Article VIII, paragraph 1.

C. Responsibility

The responsibility for reconstruction or repair after casualty shall be the same as for maintenance and repair of the condominium property, and the Association shall work with the insurance trustee to carry out the provisions of this Article.

D. Assessments

If the proceeds of insurance are not sufficient to defray the estimated costs of reconstruction or repair for which the Association is responsible, or if at any time during such reconstruction or repair, or upon completion of such reconstruction or repair, the funds for the payment of the costs thereof are insufficient, assessments shall be made against all Unit Owners in sufficient amounts to provide funds to the payment of such costs. Such assessments shall be in proportion to the Owner's percentage of interest in the General Common Elements.

E. Construction Funds

The funds for payment of costs of reconstruction or repair after casualty, which shall consist of proceeds of insurance held by the insurance trustee and funds collected by the Association from assessments against Unit Owners, shall be disbursed in the sound discretion of the trustee and according to the contract of reconstruction or repair, which contract must have the approval of the Board and the Unit Owners involved.

F. Surplus

It shall be presumed that the first monies disbursed in payment of costs of reconstruction and repair shall be from the insurance proceeds. If there is a balance in a construction fund after payment of all costs of the reconstruction and repair for which the fund is established, such balance shall be paid to the Association for the use and benefit of the Unit Owners.

Unit Owner's Insurance

Unit Owners shall be individually responsible for insuring the personal property and other contents of their Unit and for obtaining general liability insurance to cover claims incurred or accrued within a Unit. Depending on the extent of coverage of the insurance obtained by the Association as provided above, Unit Owners may also have the responsibility for insuring the boundaries of their Units. It is also recommended that Unit Owners obtain "loss assessment" coverage to help defray the costs of possible special assessments to pay for costs not covered by the Association's insurance in the event of casualty. Prior to the division of Units 1585 and/or 1595, the Unit Owners may decide to separately insure the entire Units.

X.

REMOVAL OR PARTITION

Consent to Removal

All of the Unit Owners may remove the Property from condominium ownership by executing and recording an instrument to that effect if the holders of all liens affecting any of the Units consent thereto or agree, in either case by instruments duly recorded, that their liens be transferred to the undivided interest of the Unit Owner in the Property after removal from condominium ownership.

Obsolescence, Damage and Destruction

If ninety percent (90%) of the aggregate voting interest of the Unit Owners agree that the Property is obsolete in whole or in part and that the Property should be renewed and restored, the expense thereof shall be paid by all the Unit Owners as Common Expenses. If ninety percent (90%) of the aggregate voting interest of the Unit Owners agree that the Property is obsolete in whole or in part and that the Property should be sold,

the Property shall be considered removed from condominium ownership. If within 60 days after the date of the damage to or destruction of all or part of the Property the Association does not decide to repair, reconstruct, or rebuild, the Property shall be considered removed from condominium ownership.

Condemnation Representation

For all condemnation issues concerning the Condominium, the Association shall represent the Unit Owners in the condemnation proceedings or in negotiations, settlements and agreements with the condemning authority for acquisition of the Common Elements, or part thereof, by the condemning authority. Each Unit Owner hereby appoints the Association as attorney-in-fact for such purpose.

Effect of Removal - Ownership in Common - Liens - Sale

If the Property is removed from condominium ownership as provided in this Article, the Property shall be considered owned in common by all the Unit Owners. The percentage of undivided interest of each Unit Owner in the Property owned in common shall be the same as the percentage of undivided interest previously owned by such Owner in the Common Elements. Liens affecting any Unit shall be liens, in accordance with the then existing priorities, against the undivided interest of the Unit Owner in the Property owned in common. If the Property is removed from condominium ownership as provided in this Article, it shall be subject to an action for partition at the suit of any Unit Owner. The net proceeds of sale, together with the net proceeds of the insurance on the Property, if any, shall be considered as one fund and shall be divided among the Unit Owners in proportion to their respective undivided interests after first paying out of the respective shares of the Unit Owners, to the extent sufficient for the purpose, all liens on the undivided interest in the Property owned by each Unit Owner.

XI.

NOTICE TO MORTGAGEES

A holder, insurer or guarantor of a first mortgage, upon written request to the Association, (such request to state the name and address of such holder, insurer or guarantor and the unit number), will be entitled to timely written notice of:

- a. Any proposed termination of the condominium regime;
- b. Any condemnation loss or any casualty loss which affects a material portion of the NORTH BOWL CONDOMINIUM or which affects any Unit on which there is a first mortgage held, insured or guaranteed by such eligible holder;

c. Any delinquency in the payment of assessments or charges owed by an Owner of a Unit subject to the mortgage of such eligible holder, insurer or guarantor, where such delinquency has continued for a period of sixty (60) days; and

d. Any lapse, cancellation or material modification of any insurance policy maintained by the Association.

XII.

REMEDIES

All remedies provided in this Declaration and Bylaws shall not be exclusive of any other remedies which may now be, or are hereafter, available to the parties hereto as provided for by law. The Association and any aggrieved Unit Owner has a right of action against Unit Owners for failure to comply with the provisions of the Declaration and/or Bylaws or with decisions of the Association which are made pursuant to authority granted the Association by the Declaration and Bylaws. Unit Owners also have a right of action against the Association for failing to comply with the provisions of the Declaration and/or Bylaws.

XII.

SEVERABILITY

The provisions hereof shall be deemed independent and severable and the invalidity, partial invalidity or unenforceability of any one or more provisions shall not affect the validity or enforceability of any other provision hereof.

XIII.

INTERPRETATION

The provisions of the Declaration and of the Bylaws to be promulgated and recorded herewith, shall be liberally construed to effectuate the purpose of the Declaration and Bylaws and to create Buildings subject to and under the provisions of the Unit Ownership Act.

XIV.

MISCELLANEOUS

Utility Easements

In addition to the easements provided for herein, easements are reserved through the condominium Property as may be required for utility services, including heat, air

conditioning, water, sewer, power, telephone, natural gas and cable television, in order to serve NORTH BOWL CONDOMINIUM adequately. However, such easements through the Property shall be only according to the recorded plans and specifications or as the Buildings are constructed, unless approved in writing by the Unit Owner.

Right of Access

The Association shall have the irrevocable right, to be exercised by the Manager or Board of Directors, to have access to each Unit from time to time during reasonable hours as may be necessary for the maintenance, repair or replacement of any of the Limited Common Elements therein or accessible therefrom, or for making emergency repairs therein necessary to prevent damage to the general or Limited Common Elements or to any other Unit.

Damage to the interior or any part of the Unit resulting from maintenance, repair, emergency repair or replacement of any of the general or Limited Common Elements, or as a result of an emergency repair within another Unit at the instance of the Association, shall be designated either limited or general Common Expenses by the Association and assessed in accordance with such designation.

Expenditures

No single expenditure or debt in excess of \$20,000.00 may be made or incurred by the Association or Manager without the prior approval of the majority of the Unit ownership percentage.

Benefit

Except as otherwise provided herein, this Declaration shall be binding upon and shall inure to the benefit of the Declarant, the Association and each Unit Owner, and the heirs, personal representatives, successors and assigns of each. Except as specifically provided herein regarding mortgagees, there are no third party beneficiaries intended under this Declaration.

Service of Process

The name and address of the person to receive service of process for NORTH BOWL CONDOMINIUM until another designation is filed of record shall be:

JASON ZALAC
1924 W. Stevens Suite 201
Bozeman, MT 59718

Municipal Facilities Exemption

Declarant certifies that NORTH BOWL CONDOMINIUM is excluded from review by the Department of Environmental Quality pursuant to 76-4-125 and 76-3-203, MCA.

76-4-125. **Land divisions excluded from review** (1) A subdivision excluded from the provisions of chapter 3 must be submitted for review according to the provisions of this part, except that the following divisions or parcels, unless the exclusions are used to evade the provisions of this part, are not subject to review:

(d) as certified pursuant to 76-4-127 (iii) divisions or parcels of land that are exempt from the Montana Subdivision and Platting Act review under 76-3-203.

76-3-203. **Exemption for certain condominiums and townhouses.** Condominiums, townhomes, townhouses, or conversions, as those terms are defined in 70-23-102, constructed on land subdivided in compliance with parts 5 and 6 of this chapter or on lots within incorporated cities and towns are exempt from the provisions of this chapter if:

(2) the condominium, townhome, or townhouse proposal is in conformance with applicable local zoning regulations when local zoning regulations are in effect.

Warranties

The Declarant expressly makes no warranties or representations concerning the property, the Units, the Declaration, Bylaws, or deeds of conveyance except as specifically set forth therein, and no one may rely upon such warranty or representation not so specifically expressed therein. Estimates of Common Expenses are deemed accurate, but no warranty or guarantee is made or is intended, nor may one be relied upon.

[SIGNATURE ON FOLLOWING PAGE]

DECLARANT:

PROWELL I, LLC, a Montana limited liability company, by

HOOKS RANCH LLC, a Wyoming limited liability company, Manager, by

Michael S. Hooks
Michael S. Hooks, Member

STATE OF Montana)
: ss.
County of Sweet Grass)

On this 8th day of June, 2023, before me, a Notary Public in and for said State, personally appeared MICHAEL S. HOOKS, Member of HOOKS RANCH LLC, a Wyoming limited liability company, Manager of PROWELL I, LLC, a Montana limited liability company, known to me to be the person whose name is subscribed to the within instrument and acknowledged to me that the company executed the same.

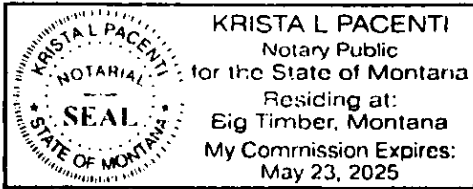

Krista L Pacenti
Printed Name: Krista L Pacenti
Notary Public for the State of Montana
Residing at Big Timber, Montana
My commission expires: May 23, 2025

CONDOMINIUM REVIEW DECISION

Project Information

Date: June 29, 2023
Number of Units total / this phase: 25
File Number: 23171
Original Project File number, If applicable: 18446
Condominium Name: North Bowl Condominiums
Legal Description: Annie Subdivision Phase 2, S02, T02 S, R05 E, Lot 5B, Acres 1.5387, Plat J-204-A

Review Planner: Elizabeth Cramblet

STATUTE:

76-3-203. Exemption for certain condominiums. Condominiums constructed on land subdivided in compliance with parts 5 and 6 of this chapter or on lots within incorporated cities and towns are exempt from the provisions of this chapter if:
(1) the approval of the original subdivision of land expressly contemplated the construction of the condominiums and any applicable park dedication requirements in 76 -3-621 are complied with; or
(2) the condominium proposal is in conformance with applicable local zoning regulations when local zoning regulations are in effect."

FINDINGS:

Per the above statute, the Department of Community Development finds the condominium development noted above meets the Subdivision & Platting Act (SPA) and Sanitation in Subdivision Act (SiS) by:

- SPA) Does not require subdivision review and has satisfied the exemption criteria.
SPA) Has completed review as a subdivision.
SiS) A municipal facilities exemption has been granted (see attached).
SiS) Exempt from Sanitation Review per:

DEPARTMENT APPROVAL:

Brian Krueger

* Digitally signed by Brian Krueger
DN: C=US, E=bkrueger@bozeman.net, O=City of Bozeman, OU=Department of Community Development, CN=Brian Krueger
Date: 2023.07.06 10:09:21-06'00'

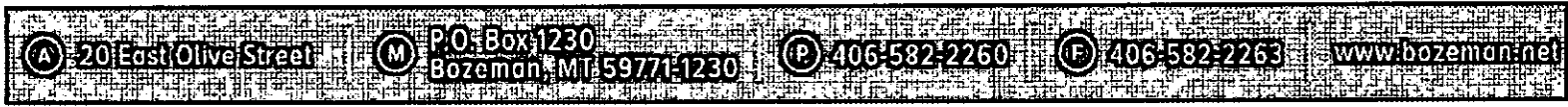



June 29, 2023

Matt Holbrook
IMEG Corp
1143 Stoneridge Drive Suite 1
Bozeman MT 59718

RE: North Bowl Condominium
Municipal Facilities Exclusion
EQ# 23-2682
City of Bozeman
Gallatin County

Dear Mr. Holbrook;

This is to certify that the information and fees received by the Department of Environmental Quality relating to this subdivision are in compliance with 76-4-127, MCA. Under 76-4-125(1)(d), MCA, this subdivision is not subject to review, and the Declaration can be filed with the county clerk and recorder.

Plans and specifications must be submitted when extensions of municipal facilities for the supply of water or disposal of sewage are proposed 76-4-131. Construction of water or sewer extensions prior to DEQ, Public Water Supply Section's approval is prohibited, and is subject to penalty as prescribed in Title 75, Chapter 6 and Title 76, Chapter 4.

North Bowl Condominium Municipal Facilities Exclusion will consist of 25 Units.

Sincerely,

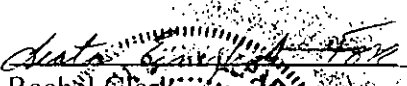
Rachel Clark
Engineering Bureau Chief
Water Quality Division
Department of Environmental Quality
(406) 444-1277
Email rachel.clark@mt.gov

cc: City Engineer
County Sanitarian
file

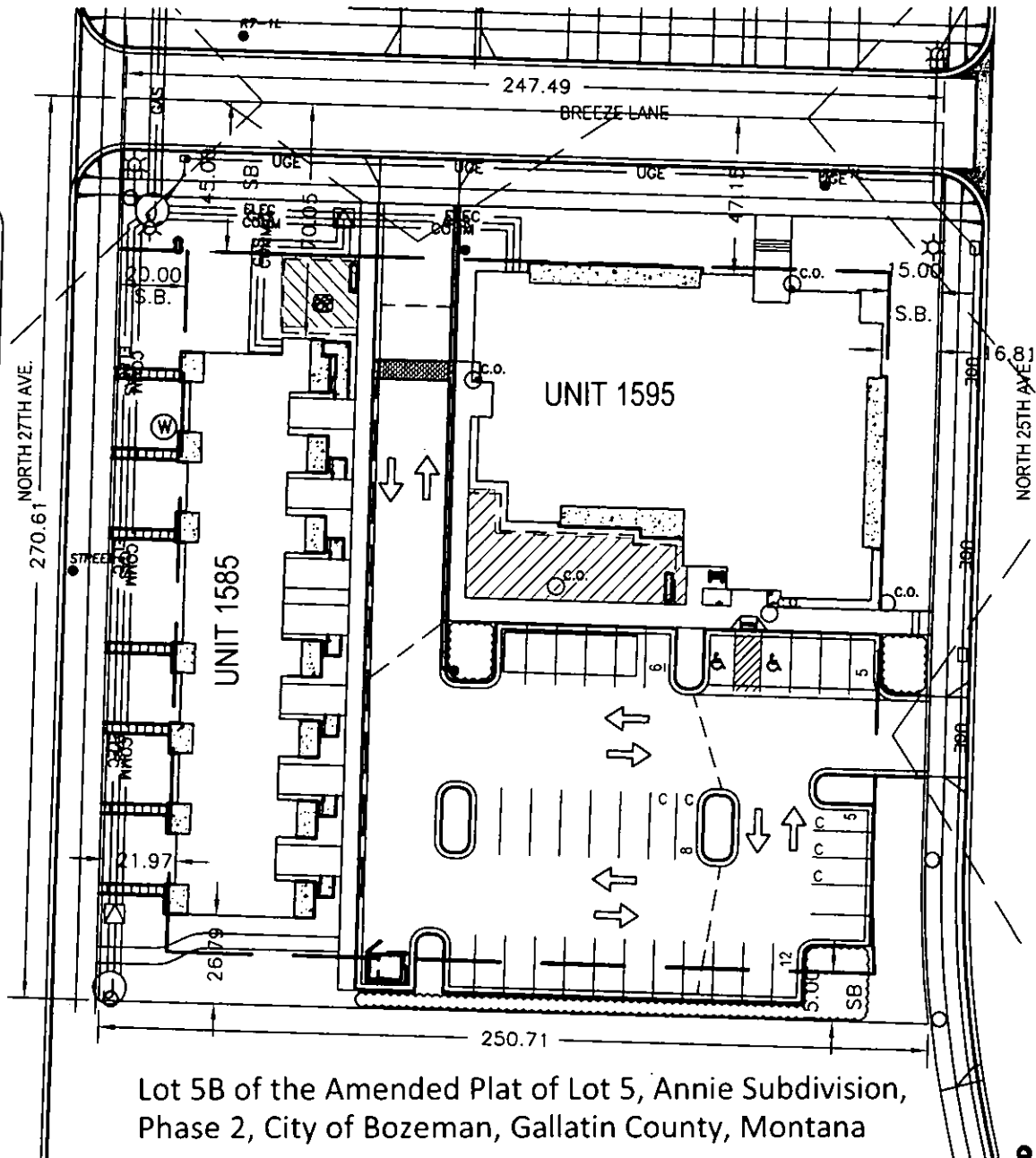

Lot 5B of the Amended Plat of Lot 5, Annie Subdivision, Phase 2, City of Bozeman, Gallatin County, Montana

1 SITE PLAN
SCALE: 1" = 50'-0"



**NORTH BOWL
CONDOMINIUM**

**BECHTLE
ARCHITECTS**

4515 Valley Commons Drive, #201
Bozeman, Montana 59718
phone (408) 585-4181 fax (408) 585-0919

EXHIBIT PLANS

A

03/21/23

JOB: 2106

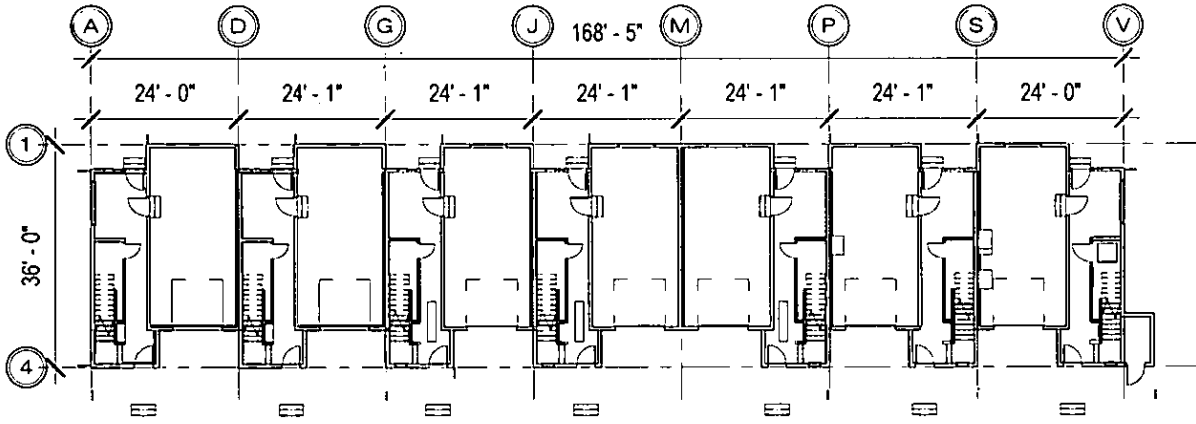

1 UNIT 1585 - 1ST FLOOR

SCALE: 1" = 30'-0"

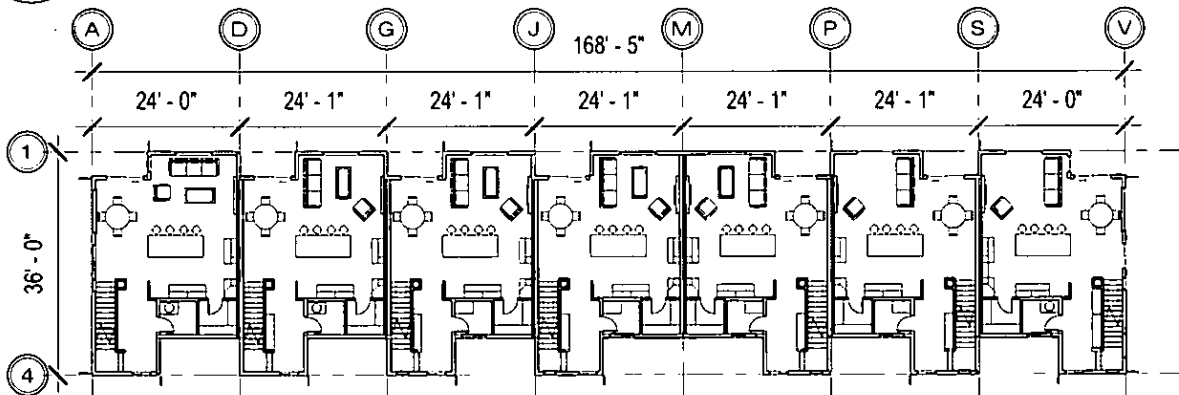

2 UNIT 1585 - 2ND FLOOR

SCALE: 1" = 30'-0"

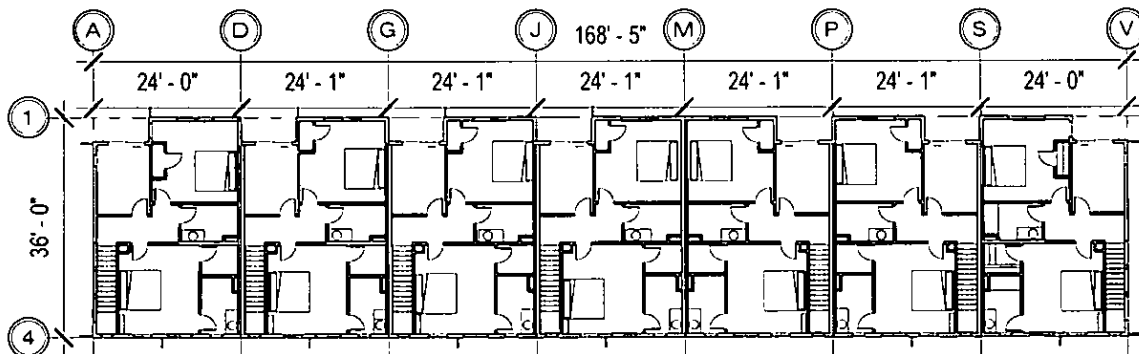

3 UNIT 1585 - 3RD FLOOR

SCALE: 1" = 30'-0"



OVERALL BUILDING AREA:	
LOWER LEVEL:	2183 SF
MAIN LEVEL:	5316 SF
UPPER LEVEL:	5862 SF
GARAGE:	3145 SF
TOTAL:	16506 SF

**NORTH BOWL
CONDOMINIUM**

**BECHTLE
ARCHITECTS**

EXHIBIT PLANS

B1

03/21/23

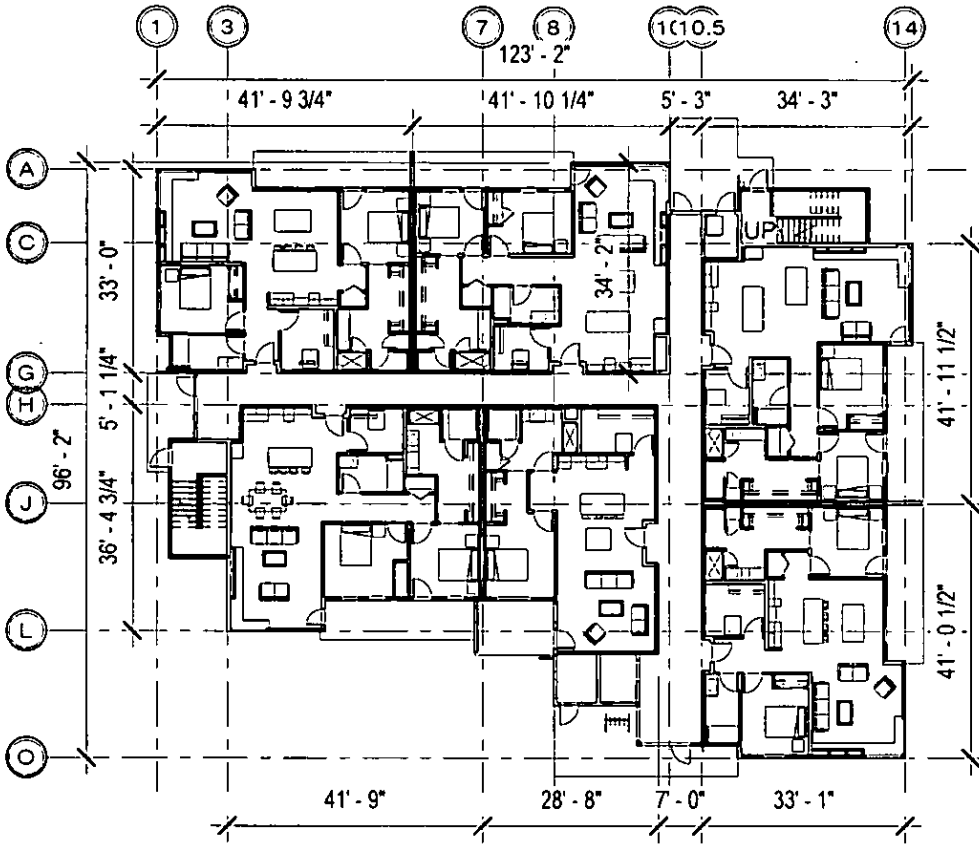

1 UNIT 1595 - 1ST FLOOR
SCALE: 1" = 30'-0"



BUILDING AREA:	
MAIN LEVEL:	9,197 SF
SECOND LEVEL:	9,069 SF
THIRD LEVEL:	9,069 SF
TOTAL:	27,335 SF

**NORTH BOWL
CONDOMINIUM**

**BECHTLE
ARCHITECTS**

4515 Valley Commons Drive, #201
Bozeman, Montana 59718
phone (406) 585-1161 fax (406) 585-6919

EXHIBIT PLANS

B2

03/21/23

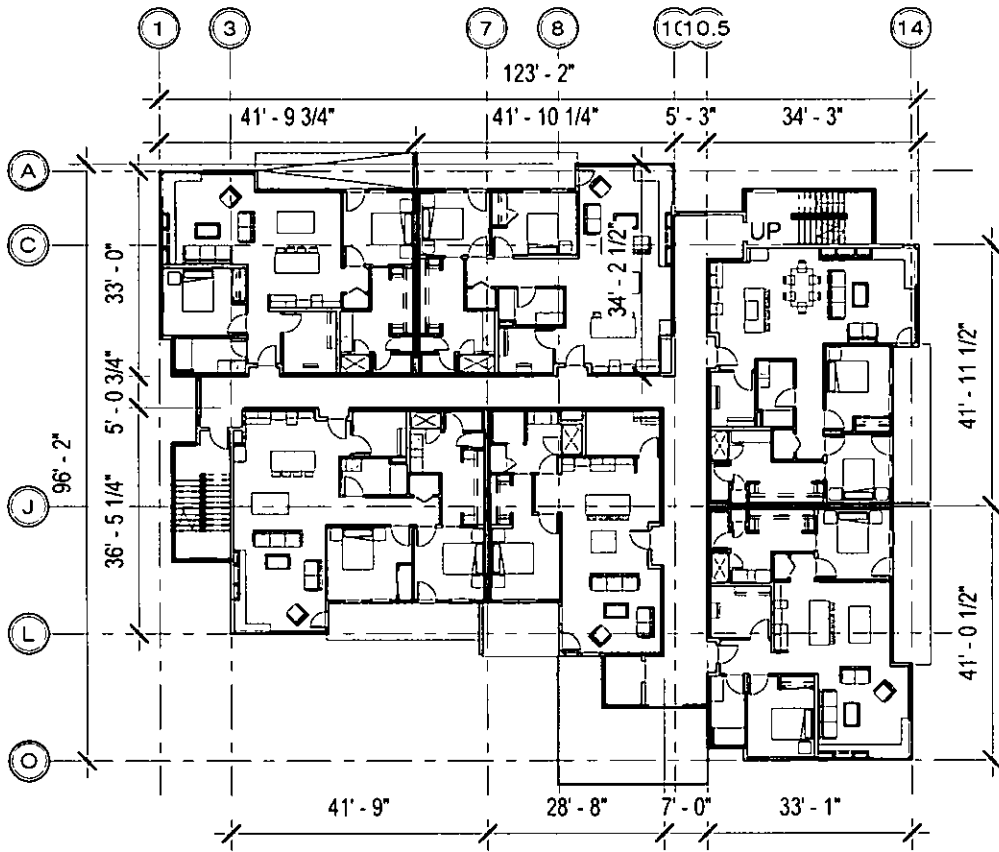

1 UNIT 1595 - 2ND FLOOR
 SCALE: 1" = 30'-0"



**NORTH BOWL
 CONDOMINIUM**

**BECHTLE
 ARCHITECTS**

EXHIBIT PLANS

B3

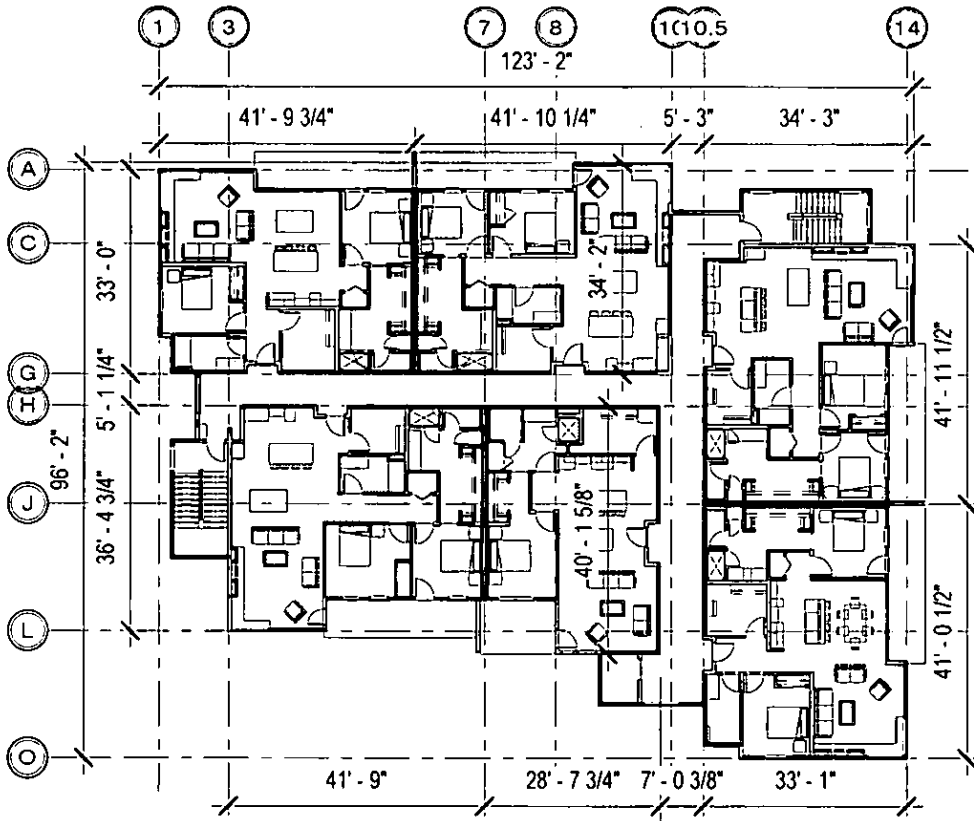

1 UNIT 1595 - 3RD FLOOR
 SCALE: 1" = 30'-0"



**NORTH BOWL
 CONDOMINIUM**

**BECHTLE
 ARCHITECTS**

EXHIBIT PLANS

B4

STORMWATER MAINTENANCE PLAN FOR PALISADES APARTMENT COMPLEX

The following areas, facilities will be inspected and the identified deficiencies shall be corrected. Clean-out must include the removal and legal disposal of any accumulated sediments and debris from the entire stormwater management system.

Storm Water Facilities:

1. Retention Ponds/Detention Ponds:

Inspect ponds annually and after major storms (following three days of dry weather after a storm event exceeding ¼ inch of precipitation.) and correct any identified deficiencies to ensure that it is working in its intended fashion and that it is free of trash and debris. Failure for water to percolate or pass through outlet structure within this time period indicates clogging or poor-draining soils. Replace/repair as necessary. Remove and properly dispose of any accumulated sediment or debris as needed. Inspect the embankments and drainage structures for settlement, slope erosion, and downstream swamping.

Mow the embankment to control woody vegetation. Remove woody debris from the bottom of the pond. Inspect for channelization at bottom of pond and remove any channels observed. Regrade as required if any channels are found that are not an element of the original design. Remove grass clippings, litter, and debris from ponds.

2. Vegetated Areas:

Inspect slopes and embankments early in the growing season to identify active or potential erosion problems. Replant bare areas or areas with sparse growth. Where rill erosion is evident, armor the area with an appropriate lining or divert the erosive flows to on-site areas able to withstand the concentrated flows. The facilities will be inspected after major storms and any identified deficiencies will be corrected.

3. Ditches, Swales, Stormwater Chases and other Open Stormwater Channels:

Inspect 2 times per year (preferably in Spring and Fall) to ensure they are working in their intended fashion and that they are free of sediment and debris. Remove any obstructions to flow, including accumulated sediments and debris and vegetated growth. Repair any erosion of the ditch lining. Vegetated ditches will be mowed at least annually or otherwise maintained to control the growth of woody vegetation and maintain flow capacity. Any woody vegetation growing through riprap linings must also be removed. Repair any slumping side slopes as soon as practicable. If the ditch has a riprap lining, replace riprap on areas where any underlying filter fabric or underdrain gravel is showing through the stone or where stones have dislodged. Correct any erosion of the channel's bottom or side slopes. The facilities will be inspected after major storms and any identified deficiencies will be corrected. For concrete stormwater chase structures with metal "no slip" cover. Inspect covers to ensure metal edges aren't protruding above the concrete surface. Correct deficiencies if found. Repair damaged or badly cracked stormwater chases if observed.

Standard Maintenance Summary:

1. Remove sediment and oil/grease from retention ponds.

2. Inspect and remove debris from drainage swales, catch basins, and detention ponds.
3. Monitor health of vegetation and revegetate as necessary to maintain full vegetative cover.
4. Inspect for the following issues: differential accumulation of sediment, drain time, signs of petroleum hydrocarbon contamination (odors, oil sheen in pond water), standing water, trash and debris blockages.

Note on sediment disposal:

In most cases, sediment from a detention pond does not contain toxins at levels posing a hazardous concern. However, sediments should be tested for toxicants in compliance with current disposal requirements and if land uses in the drainage area include commercial or industrial zones, or if visual or olfactory indications of pollution are noticed. Sediments containing high levels of pollutants should be disposed of in accordance with applicable regulations and the potential sources of contamination should be investigated and contamination practices terminated.

ACCEPTED BY PALISADES APARTMENT COMPLEX OWNERS ASSOCIATION, BY

Signature: _____ Date: _____

Printed Name: _____

EXHIBIT C

BYLAWS
OF THE
NORTH BOWL CONDOMINIUM OWNERS ASSOCIATION

TABLE OF CONTENTS

PURPOSE AND APPLICATION	1
MEMBERSHIP	1
OBLIGATIONS	1
MEETING AND VOTING	2
VOTING INTEREST	2
BOARD OF DIRECTORS	3
OFFICERS OF THE BOARD OF DIRECTORS	3
POWERS AND DUTIES OF BOARD OF DIRECTOR	4
VACANCIES AND REMOVAL	6
COMPENSATION	6
MANAGER	6
AMENDMENT OF BYLAWS	8
ASSESSMENTS	8
THE DECLARATION	9

I.

PURPOSE AND APPLICATION

These Articles are and shall be the Bylaws of the NORTH BOWL CONDOMINIUM OWNERS ASSOCIATION. These Bylaws shall, upon being recorded with the Clerk and Recorder of Gallatin County, State of Montana, govern and control the administration of NORTH BOWL CONDOMINIUM. All Unit Owners, their guests, invitees and any renters or sublessees, present and future, shall have the rights and responsibilities described in these Bylaws and shall be subject to the provisions thereof. The acquisition of an ownership interest in a Unit in NORTH BOWL CONDOMINIUM signifies that the Owner accepts, ratifies and agrees to comply with these Bylaws.

II.

MEMBERSHIP

Persons owning a Unit in NORTH BOWL CONDOMINIUM or an interest in a Unit, or owning a Unit in any real estate tenancy relationship recognized by the State of Montana, shall be a member of the Association. An owner may not decline membership in the Association. Membership begins concurrently with the acquisition of an ownership interest and terminates at the time such ownership interest is terminated. Such termination shall not relieve any owner of liability for obligations incurred while a member of the Association; further, membership in the Association does not in any way negate or impair any owner's legal remedies, right to bring legal action, or defenses to any and all actions involving the Association, other Unit Owners, or the Management, which may arise from or be incidents of unit ownership.

III.

OBLIGATIONS

Each Unit Owner shall be obligated to comply with these Bylaws, the Declaration, and the laws of the City of Bozeman, County of Gallatin, the State of Montana and any other governing body with jurisdiction. Such obligations shall include, but not be limited to, the paying of assessments levied by the Association, and the adherence to the protective covenants which are a part of the Declaration. Failure of any owner to abide by these Bylaws, and all rules made pursuant thereto, the Declaration, and the laws of the City of Bozeman, the County of Gallatin, and the State of Montana, shall be grounds for appropriate legal action by the Association or by an aggrieved Unit Owner against such noncomplying Owner subject to the requirements of the Arbitration Agreement in the Declaration. Each Unit Owner shall also comply with any applicable subdivision covenants, rules and regulations for the subdivision in which the Condominium is located.

IV.

MEETING AND VOTING

There shall be a regular meeting of the Association annually at a date, time, and place fixed by the Board. The first annual meeting shall be called by the Declarant and held within ninety (90) days of the closing of the sale of ninety percent (90%) of the Units of the condominium.

Pursuant to these Bylaws, the Association may at any time hold special meetings. Such special meetings may be called: on the initiative of the President of the Association; by the Board of Directors; by a signed request of the Manager; or by a petition signed by Unit Owners representing at least fifty percent (50%) of the Unit voting interest in the Condominium. Notice of any special meeting must specify the reason for such meeting and the matters to be raised. Only matters set forth in the petition or request may be brought before such meeting unless at least fifty percent (50%) of the Unit voting interest present agree otherwise.

A. Notice.

Notice of all meetings, regular or special, shall be mailed or emailed by the Association's Secretary to every Unit Owner of record at his address or email address of record at least ten (10) business days prior to the time for holding such meeting. Such notice shall specify the date, time and place of the meeting and shall make provisions to allow for the voting of each Unit Owner's interest by proxy at the discretion of the owner. The mailing or emailing of a notice in the manner provided in this paragraph or the personal delivery of such notice by the Secretary of the Association shall be considered as notice served.

B. Quorum.

No meeting, regular or special, shall be convened to conduct business unless a quorum is present in person or by proxy. A quorum shall consist of at least fifty percent of the Units voting interest of NORTH BOWL CONDOMINIUM. A Unit Owner may participate in any meeting by means of a conference telephone or similar communication equipment through which all persons participating in the meeting may communicate with the other participants. Participation in a meeting pursuant to this section constitutes presence in person at the meeting. At any time, during any meeting that a quorum is not present, such meeting shall be adjourned forthwith.

V.

VOTING INTEREST

Each Unit at Association meetings shall have a voting interest equal to that Unit's

ownership interest percentage in the General Common Elements as set forth in the Declaration, a copy of which is being filed concurrently with the filing of these Bylaws with the Clerk and Recorder of Gallatin County, State of Montana. In the event that Unit Owners of the same Unit cannot agree as to how to vote that Unit's interest, said Unit's vote shall be suspended for that particular matter. Voting upon matters affecting Limited Common Elements and assessments for Limited Expenses shall be only by owners having an interest in the Limited Common Element concerned. In the event that a Unit is delinquent in payment of assessments, that Unit's vote shall be suspended until such time as said delinquent assessment is brought current.

Whenever a quorum is present at a meeting of the Association or the Board of Directors, those present may do any and all acts they are empowered to do unless specific provisions of these Bylaws, the Declaration, or the laws of the State of Montana direct otherwise.

VI.

BOARD OF DIRECTORS

The governance of NORTH BOWL CONDOMINIUM shall be by a Board of three (3) Directors, elected among the Unit Owners. Until at least ninety percent (90%) of the condominium Units have been sold (in all phases), the Board shall consist of three (3) persons appointed by the Declarant, who shall serve until the first annual meeting of the Association, at which time a new Board shall be elected. The initial directors appointed by the Declarant are listed below. The Board shall have all powers and responsibilities attendant to the general administration and control of the condominium. Additionally, the Board shall have the authority necessary to carry into effect the powers and duties specified by these Bylaws.

VII.

OFFICERS OF THE BOARD OF DIRECTORS

The Association shall elect from its membership a Board of Directors which shall consist of a President, Secretary, and Treasurer, who shall all serve for a term of one (1) year. The manner of election of the Board of Directors shall be as follows:

At the first and all subsequent annual meetings of the Association, nominations for positions on the Board shall be accepted from any of the Unit Owners present. Voting will be noncumulative, with each Unit having a vote equal to said Unit's ownership percentage for each nominated person. Board members shall be elected by majority vote of the Unit ownership percentage present or voting by proxy at any annual or special meeting at which a quorum is reached.

VIII.

POWERS AND DUTIES OF THE BOARD OF DIRECTORS

The Board of Directors shall have the following powers and duties:

- A. To call annual meetings of the Association and give due notice thereof.
- B. To conduct elections of the Board of Directors.
- C. To enforce the provisions of the Declaration, Bylaws, and protective covenants of NORTH BOWL CONDOMINIUM by appropriate action.
- D. To promulgate and adopt rules and regulations for the use of the Common Elements and for the occupancy of the Units so as not to interfere with the peace and quiet of all the residents. Such rules must be approved by two-thirds the aggregate unit voting interest in the condominium at any regular or special meeting of the Association.
- E. To provide for the management of NORTH BOWL CONDOMINIUM by hiring or contracting with suitable and capable management and personnel for the day-to-day operation, maintenance, upkeep and repair of the General Common Elements and Limited Common Elements.
- F. To levy assessments as allowed by the Declaration, these Bylaws and the State of Montana, and to provide for the collection, expenditure and accounting of said assessments.
- G. To pay for the expenses of the maintenance, repair and upkeep of the General Common Elements and the Limited Common Elements, and to approve payment vouchers either at regular or special meetings.
- H. To delegate authority to the Manager for the routine conduct of condominium business, however, such authority shall be precisely defined with ultimate authority at all time residing in the Board of Directors.
- I. To provide a means of hearing grievances of Unit Owners and to respond appropriately thereto.
- J. To meet at regularly scheduled times and to hold such meetings open to all Unit Owners or their agents.
- K. To prepare an annual budget for the condominium in order to determine the amount of the assessments payable by the Unit Owners to meet the Common Expenses and Limited Expenses, and allocate and assess such

charges among the Unit Owners according to their respective interests in the General Common Elements and Limited Common Elements.

- L. To levy and collect special assessments whenever, in the opinion of the Board, it is necessary to do so in order to meet increased operating or maintenance expenses, costs, or additional capital expenses, or because of emergencies.
- M. To take appropriate legal action to collect any delinquent assessments, payments or amounts due from Unit Owners, or from any person or persons owing money to the condominium, and to levy a penalty and to charge interest on unpaid amounts due and owing. However, other than for the collection of delinquent assessments or accounts, the Board shall not initiate any litigation or lawsuit without prior approval of at least two-thirds ($\frac{2}{3}$) of the aggregate unit ownership in the condominium.
- N. To defend in the name of the Association any and all lawsuits wherein NORTH BOWL CONDOMINIUM is a party defendant.
- O. To enter into contracts necessary to carry out the duties herein set forth.
- P. To establish a bank account for NORTH BOWL CONDOMINIUM, and to keep therein all funds of the Association. Withdrawal of monies from such accounts shall only be by checks signed by such persons as are authorized by the Board of Directors.
- Q. In general, to act for and carry on the administration and affairs of the Association as authorized and prescribed by the Declaration, and to do all those things which are necessary and reasonable in order to carry out the governance and operation of NORTH BOWL CONDOMINIUM.
- R. To make repairs, alterations, additions, and improvements to the General Common Elements and Limited Common Elements consistent with managing the condominium in a first class manner and in the best interest of the Unit Owners.
- S. To provide for the perpetual maintenance of the general common open area and landscaping, the parking areas and driving lanes, and any stream/ditch and irrigation canals, and to make any assessments necessary for such maintenance as provided herein. Such maintenance shall specifically include the control of County declared noxious weeds.
- T. To arrange, keep, maintain and renew the insurance for the Association as set forth in the Declaration.

- U. If applicable, to receive and make payment for common utility expenses for all of the Units. The pro-rata portion of the utility expenses shall be paid by the unit owners as part of, or in addition to, their condominium assessment, with the method of payment to be determined by the Board.
- V. To levy fines as more particularly set forth in the Declaration.
- W. To carry out the duties and responsibilities of the Board in all other matters as may be authorized, needed or required by the Declaration.

IX.

VACANCIES AND REMOVAL

Should a vacancy occur on the Board of Directors, the Board, subject to the exception described below, shall appoint a member of the Association to serve for the unexpired term. Such vacancy shall be filled no later than the next regular Board meeting after which it occurs. Should such vacancy not be filled by the Board by the next regular meeting of the Association, the Association may fill such vacancy.

Subject to Declarant's right to appoint the members of the Board set forth above, at any regular or special meeting of the Association, any member of the Board may be removed by majority vote of the aggregate unit voting interest. Such vacancy shall be filled by the Association's members. Such removal matter must be announced in the notice of such regular or special meeting. A director appointed by the Declarant may only be replaced by the Declarant so long as the Declarant has the power and authority to appoint members of the Board.

X.

COMPENSATION

No member of the Board of Directors shall receive any compensation for acting as such. Nothing herein, however, shall be construed to preclude compensation being paid to Managers who are hired by the Board of Directors.

XI.

MANAGER

If the Board elects to hire a Manager, said Manager shall be appointed and/or removed by the Board of Directors. The Manager (or any member of the Board or Association handling Association funds or having power to withdraw or spend such funds) shall be bonded if required by the Board of Directors, and shall maintain the records of the financial affairs of the condominium.

- A. Accounts: The Manager shall keep detailed accurate records in chronological order of the receipts and expenditures affecting the Common Elements, itemizing the maintenance and repair expenses of the Common Elements and any other expenses incurred. The receipts and expenditures of the Association shall be under the direction of the Manager and be classified as appropriate into Common Expenses and Limited Expenses, and shall include a provision for current expenses which shall include all receipts and expenditures to be made within the year for which the budget is made, including a reasonable allowance for contingencies and working funds, except expenditures chargeable to reserves or betterments. The balance in this fund at the end of each year shall be applied to reduce the assessments for current expenses for the succeeding year. Other budget items may be provided for in the discretion of the Manager. All records shall be available for examination during normal business hours to any Unit Owner or his or her assigned representative. All functions and duties herein provided for the Manager may be performed by the Board, or the President, if the Board should decide not to have a Manager.
- B. Budget: The Manager shall prepare and submit to the Board each calendar year, a budget, which must be approved and adopted by the Board. The budget shall include the estimated funds required to defray the Common Expenses and Limited Expenses and to provide and maintain funds for the foregoing accounts according to good accounting practices.
- Copies of the budget and proposed assessments shall be transmitted to each Unit Owner on or before December 15 of the year preceding the year for which the budget is made.
- C. Financial Report: A financial report of the accounts of the Association may be made annually by a Certified Public Accountant, if required by the Board of Directors, and a copy of the report shall be furnished to each Unit Owner no later than March 1st of each year for which the audit is made.
- D. Audit: The Association shall prepare and furnish, within two (2) weeks of receipt of a written request from an Eligible Mortgagee, an audited financial statement of the Association for the immediately preceding year to the following agencies/corporations: United States Department of Housing and Urban Development (HUD); United States Department of Veterans Affairs (VA); Federal National Mortgage Association (FNMA); and Federal Home Loan Mortgage Corporation (FHLMC).
- E. Inspection Rights: The Association shall make available, for inspection upon request during normal business hours, to Unit Owners, lenders, prospective purchasers, and the holders and insurers of the first mortgage on any Unit, current copies of the Declaration, Bylaws and other rules governing the

Condominium, and other books, records and financial statements of the Association.

The Manager shall generally operate and manage the condominium for and on behalf of the Unit Owners and shall have such other powers and authority as the Board may designate. If there is no Manager or if the Manager resigns, is terminated or his contract expires, the Board shall perform all the duties of the Manager.

XII.

AMENDMENT OF BYLAWS

These Bylaws may be amended at any regular or special meeting of the Association. Upon a vote of at least seventy-five percent (75%) of the Unit ownership percentage, the amendment shall be declared adopted.

An amendment may also be adopted at any time without a meeting if it is approved in writing by the notarized signatures of one hundred percent (100%) of the Unit Owners.

The Secretary shall as soon as practicable after adoption, prepare a copy of the Amendment to these Bylaws for certification by the President and Secretary of the Association. Such certified amendment to the Bylaws shall then be filed and recorded in the office of the Clerk and Recorder of Gallatin County, State of Montana. An amendment to the Bylaws shall become effective at the time of such recording. No right granted to the Declarant under these Bylaws may be amended without the Declarant's written consent.

XIII.

ASSESSMENTS

In accordance with the percentage of interest in the General Common Elements as set forth in the Declaration, each Unit Owner shall be assessed for Common Expenses, which shall include the expenses of any properly created special improvement districts (SIDs) affecting the property, including, but not limited to, lighting districts, street maintenance and tree maintenance. Such assessments, and assessments for Limited Expenses, shall be collected and paid according to the terms and under the procedures more particularly set forth in the Declaration. The amount of assessments described above and any other assessments allowed by these Bylaws, the Declaration, and by the State of Montana, shall be fixed by the Board of Directors at any regular or special meeting. Notice of each Unit Owner's assessments shall be mailed to said owner at his or her address of record.

XIV.

THE DECLARATION

The undersigned has filed, along with these Bylaws, a Declaration whereby the properties known as NORTH BOWL CONDOMINIUM are submitted subject to Title 70, Chapter 23, M.C.A. The Declaration shall govern the acts, powers, duties and responsibilities of the Association, and in the event these Bylaws and the Declaration are in conflict, the Declaration shall prevail.

The definition of terms set forth in the Declaration shall be applicable throughout these Bylaws and the interpretation thereof.

By virtue of these Bylaws and the Declaration, each Unit Owner has the right to membership in the Association and any Unit Owner may be on the Board of Directors of NORTH BOWL CONDOMINIUM, subject to the conditions set forth above.

The Association and its Board of Directors shall have the primary and final authority on all matters solely affecting the condominium area, subject to the laws, rules and regulations of the County of Gallatin and the State of Montana.

IN WITNESS WHEREOF, the undersigned, as the owner of record of all of the Units of NORTH BOWL CONDOMINIUM and one hundred percent (100%) of the voting interests of NORTH BOWL CONDOMINIUM as of the date hereof, hereby appoints the following persons to serve on the Board of Directors and as officers until the first annual meeting of the Association, to-wit:

Stacy Hooks, President
Todd Goulet, Secretary
Kayla Hubbard, Treasurer

And, the Declarant hereby declare and affirm the adoption of the foregoing Bylaws on the 8 day of June, 2023.

[signature on following page]

DECLARANT:

PROWELL I, LLC, a Montana limited liability company, by

HOOKS RANCH LLC, a Wyoming limited liability company, Manager, by

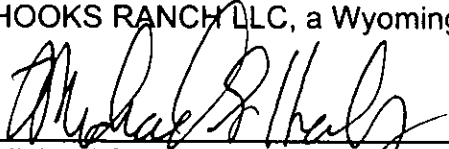

Michael S. Hooks, Member

STATE OF Montana)
: ss.
County of Sweet Grass

On this 9th day of June, 2023, before me, a Notary Public in and for said State, personally appeared MICHAEL S. HOOKS, Member of HOOKS RANCH LLC, a Wyoming limited liability company, Manager of PROWELL I, LLC, a Montana limited liability company, known to me to be the person whose name is subscribed to the within instrument and acknowledged to me that the company executed the same.

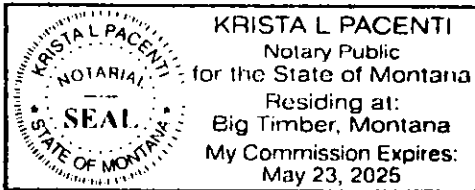



Printed Name: Krista L Pacenti
Notary Public for the State of Montana
Residing at Big Timber, Montana
My commission expires: May 23, 2025