

2597601

Page 1 of 51 11/03/2017 03:59:58 PM Fee: \$357.00
Charlotte Mills - Gallatin County, MT MISC

After recording return to:

Mindy T. Cummings, P.C.
P.O. Box 161292
Big Sky, Montana 59716

**DECLARATION
FOR
CROFT FARMS CONDOMINIUMS**

~~**DECLARATION FOR RIVER CROFT CONDOMINIUMS
AT GALLATIN RIVER FARM**~~

This DECLARATION (as supplemented, amended or restated from time to time, the "Declaration") is hereby made and entered into this 14th day of September, 2017, by FHG Construction, Incorporated, a Montana corporation (the "Declarant," as further defined in Article III of this Declaration), whereby lands and property hereinafter described are submitted and subject to the Montana Unit Ownership Act pursuant to Chapter 23, Title 70, MCA (2015), as amended.

ARTICLE I - TITLE AND NATURE

The Project shall be known by the name Croft Farms Condominiums. A Certificate of Name is attached hereto as **Exhibit F**. The Project is established in accordance with the Unit Ownership Act. The Project may contain up to twenty (20) individual Units for residential use, as set forth herein, and each Unit is capable of individual utilization on account of having its own entrance from and exit to a Common Element. Each Unit Owner shall have an exclusive right to such Unit Owner's Unit. Each Unit Owner shall have an undivided and inseparable interest in the Common Elements and the right to share with other Unit Owners the General Common Elements of the Project as set forth in this Declaration.

ARTICLE II - PURPOSE AND OWNERSHIP

2.1 The purpose of this Declaration is to divide the Property into twenty (20) individual residential Units by submitting the Property and the improvements existing and to be constructed on the Property to the condominium form of ownership and use in the manner provided by the Unit Ownership Act. Declarant currently intends to develop the Property as part of a larger, integrated community known as Gallatin River Farm North.

2.2 The Property is located in Gallatin County, Montana. The Property that is subject to this Declaration is owned by Declarant as of the date of this Declaration.

ARTICLE III - DEFINITIONS

Unless the context expressly provides otherwise, the following definitions shall pertain throughout this Declaration and in the interpretation thereof:

3.1 **Annexable Property**: has the meaning given in Section 10.5.

3.2 **Articles**: means the Articles of Incorporation of the Association, as the same may be amended, restated or replaced from time to time.

3.3 **Association**: means all of the Unit Owners acting as a group and in accordance with duly adopted Bylaws and this Declaration, also referred to as the Croft Farms Condominium Owners' Association, a Montana nonprofit corporation, and any successor thereto.

3.4 **Board**: means the Board of Directors of the Association as more particularly defined in the Bylaws.

3.5 **Building:** means the structures containing the Units. The Buildings are more particularly described in Section 5.4.

3.6 **Bylaws:** means the Bylaws of the Association, as the same may be amended, restated or replaced from time to time.

3.7 **Construction Activity:** means any site preparation, landscaping, sign erection, construction, reconstruction, change, modification, alteration, enlargement or material maintenance of any Improvements or real property, or any physical changes in the use of any Unit or other property or building or structure thereon, interior or exterior.

3.8 **Common Elements:** means both General Common Elements and Limited Common Elements. For the avoidance of doubt, the Common Elements do not include the Units or any portion thereof.

3.8.1 **General Common Elements:** means all those elements within the Project which are for the use of all Unit Owners and their guests and invitees. The Declarant or the Association (with consent of the Declarant during the Declarant Control Period) may add or delete General Common Elements by amendments to this Declaration and/or by the method set forth in the Unit Ownership Act. The General Common Elements include, but are not limited to, the following to the extent not within a Unit and not otherwise designated as a Limited Common Element:

3.8.1.1. the land on which the Buildings are located, except any portion thereof included in a Unit or made a Limited Common Element by this Declaration or amendment hereto;

3.8.1.2. the foundations, columns, girders, beams, supports, mainwalls, roofs and other structural components of the Buildings, stairs, fire escapes, entrances and exits of Buildings, and the siding and other exterior surfaces of the Buildings;

3.8.1.3. the outside recreational areas, parking spaces, roads, sidewalks and paths;

3.8.1.4. installations of central services existing for common use of all Units or all Units within a Building such as power, light, gas, television, telephone, hot and cold water, sewer, heating, refrigeration, air conditioning, waste collection and disposal and other utilities and connections to the extent serving all Units;

3.8.1.5. public utility lines, water, sewer, electrical, gas, telephone and television lines, propane tanks and similar infrastructure and facilities to the extent serving all Units or all Units within a Building;

3.8.1.6. the tanks, pumps, motors, fans, compressors, ducts and in general all apparatus and installations existing for common use of all Units or of all Units within a Building;

3.8.1.7. any facilities and improvements constructed on the Property for operation and maintenance of the Project or use by all Unit Owners; and

3.8.1.8. landscaping, landscape irrigation, wells, landscape and development lighting, road and driveway lighting, security lighting, Project signage and signage lighting (if installed), mailbox cluster, common trash enclosure (if installed), street signage, retaining walls, plans and other materials and improvements separate from and outside of the Units, and other elements necessary for or convenient to the safety, maintenance and existence of the Project.

3.8.2 Limited Common Elements: means those Common Elements within the Project designated in this Declaration, site plan, or floor plans or by agreement of the Unit Owners which are reserved for the use of a certain Unit or Building or number of Units or Buildings to the exclusion of the other Units or Buildings. Specifically, as to any given Unit or Building, Limited Common Elements shall include, but not be limited to, the following common elements which are outside the boundaries of the Unit and which are appurtenant to, affixed to or provide service or access to the Building containing the Unit:

3.8.2.1. Driveways (used for ingress and egress between a Roadway and a Unit), paths, entrances, walkways, stoops, decks, porches and patios; and

3.8.2.2. any other improvement, facility or item described in the definition of General Common Elements to the extent serving less than all Units or Buildings.

3.9 **Common Expenses**: means expenses of construction (not including initial construction by Declarant as part of the initial development of the Project), administration, operation, maintenance, repair or replacement of General Common Elements, and, unless otherwise determined by the Board, Limited Common Elements to the extent the Association is responsible for construction (not including initial construction by Declarant as part of the initial development of the Project), administration, operation, maintenance, repair or replacement thereof, and all other expenses for the benefit of the Association as a whole, all expenses declared common by the Unit Ownership Act (but specifically excluding Limited Expenses) and any reserve established by the Board to the extent relating to the General Common Elements, the Limited Common Elements for which the Association is responsible or otherwise for the benefit of the Association as a whole.

3.10 **Community Association**: means the Gallatin River Farm North Homeowners' Association, a Montana nonprofit corporation, its successors and assigns.

3.11 **Condominium Documents**: means this Declaration, the Articles, the Bylaws, any Rules and Regulations and any and all other documents necessary for the formation of the Project, including, but not limited to, any surveys, plats, or plans.

3.12 **Declarant**: means FHG Construction, Incorporated, a Montana corporation, and its successors and assigns. Both successors and assigns shall always be deemed to be included within the term "Declarant" whenever, however and wherever such term is used in the Condominium Documents. No party other than FHG Construction, Incorporated shall exercise the rights and privileges of the Declarant unless such party receives from the then-existing

Declarant and records in the office of the Clerk and Recorder of Gallatin County, Montana a written instrument assigning such rights.

3.13 **Declarant Control Period:** means the period of time commencing with the recording of this Declaration with the office of the Clerk and Recorder of Gallatin County, Montana, and ending on the earlier of (i) when Declarant determines, in an instrument recorded with the office of the Clerk and Recorder of Gallatin County, Montana, that more than ninety-five percent (95%) of the Units (including any Units which may ultimately be annexed into and become a part of the Project) have been sold or conveyed to persons or entities other than Declarant or its affiliates, and (ii) any earlier date on which Declarant records an instrument with the office of the Clerk and Recorder of Gallatin County, Montana specifying that the Declarant Control Period has ended.

3.14 **Declaration:** has the meaning given in the first paragraph hereof.

3.15 **Design Guidelines:** means those Architectural Standards and Design Guidelines that may be adopted by the DRC pursuant to the Gallatin River Farm CC&Rs.

3.16 **DRC:** means the Design Review Committee of the Community Association established pursuant to the Gallatin River Farm CC&Rs.

3.17 **Driveway:** means, with respect to each Building, those Limited Common Elements used for ingress and egress between a roadway and the Building serving one or more Units.

3.18 **Facility:** means any real estate or Improvement within the Property (a) that is owned by the Association or (b) that is part of the Property designated by Declarant as a Facility herein or on a Plat, for the use or benefit of one or more Unit Owner.

3.19 **Gallatin River Farm Community:** means the community that consists of the properties within Gallatin River Farm North Major Subdivision, Phases 1 and 2 on file with the office of the Clerk and Recorder of Gallatin County, Montana [Plat References: J-491 and J-504].

3.20 **Gallatin River Farm CC&Rs:** means the Declaration of Protective Covenants and Restrictions for the Gallatin River Farm, dated March 27, 2008, and recorded with the office of the Clerk and Recorder of Gallatin County, Montana on May 8, 2008, as Document No. 2299461, as supplemented, amended, restated or replaced from time to time.

3.21 **Gallatin River Farm Governing Documents:** means the Gallatin River Farm CC&Rs, the Articles of Incorporation and Bylaws of the Community Association (as amended, restated or replaced from time to time), the rules, regulations, policies, decisions and resolutions of the Community Association and its board of directors and the Design Guidelines.

3.22 **Governing Documents:** means the Condominium Documents and the Gallatin River Farm Governing Documents.

3.23 **Insurance Trustee:** has the meaning given in Section 13.4.

3.24 **Improvements:** means all structures and appurtenances thereto of every type and kind, including but not limited to, buildings, outbuildings, all exterior surfaces including the surface finish thereof; security systems; mailbox structures; decks; canopies; patios; awnings; gardens; sprinkler systems and other landscaping; planting, clearing, or removing of trees, shrubs, grass, or plants and appurtenances; ponds and water tanks; drainage, detention, retention facilities and culverts; monuments; recreational areas, amenities and facilities; clubhouses; facilities to accommodate invitees and visitors; central waste collection and disposal facilities; paving and parking areas; malls; ducts; shafts and flues; conduit installation areas; storage facilities for supplies and equipment; fences; gates; fire breaks and fire prevention works; screening walls; earth walls, retaining walls, cuts and fills associated with any improvements; lighting; signage; pipelines, lift stations, pumps; utilities of any sort; Antennae; communication facilities and lines; management offices; environmental monitoring equipment and facilities; ground water facilities; waterways; the demolition or destruction by voluntary action of any structure or appurtenance thereto of every type and kind; grading, excavation, filling, or similar disturbance to the surface of the land including, but not limited to, change of grade, change of ground level, change of drainage pattern, change of stream bed or change of any existing surface contour; equipment related to the foregoing; and all types of structures, facilities and improvements that a governmental or quasi-governmental entity may be empowered by law from time to time to construct.

3.25 **Limited Expenses:** means the expenses attributable to the construction (not including initial construction by Declarant as part of the initial development of the Project), administration, operation, maintenance, repair and replacement of Limited Common Elements; provided, however, that, unless otherwise determined by the Board, such costs shall be Common Expenses to the extent the Association is responsible for the construction (not including initial construction by Declarant as part of the initial development of the Project), administration, operation, maintenance, repair and replacement of such Limited Common Elements.

3.26 **Manager:** means the Board, a manager, a management corporation or any other person or group of persons retained or appointed by the Board, or by the Association, for the purpose of conducting the day-to-day operations of the Project.

3.27 **Other Projects:** means other developments or phases within the Gallatin River Farm Community.

3.28 **Percentage of Interest:** means each Unit Owner's undivided interest in the Common Elements and such Unit Owner's pro rata liability to the Association. The Percentage of Interest with respect to each Unit is specified on **Exhibit E** attached hereto.

3.29 **Permitted Household Pets:** has the meaning given in Section 12.4.

3.30 **Plans:** has the meaning given in Section 5.1.2.

3.31 **Plat:** means the plat of Gallatin River Farm North Major Subdivision, Phase 2, Final Plat on file with the office of the Clerk and Recorder of Gallatin County, Montana [Plat Reference: J-504].

3.32 **Project:** means the Property and all buildings, improvements and structures thereon and all easements, rights and appurtenances belonging thereto, which are herewith submitted to the Unit Ownership Act.

3.33 **Property:** means the real property located in Gallatin County, Montana and described on **Exhibit A** attached hereto, along with any property subsequently annexed or otherwise subjected to this Declaration.

3.34 **Rules and Regulations:** means the specific rules, regulations and policies that may be adopted by the Board from time to time for governance and management of the Project.

3.35 **Units:** means the separate condominium units of the Project each of which is a parcel of property including and containing one or more rooms, intended for independent residential use, and with a direct exit leading to a public street or to Common Elements leading to a public street whether directly or indirectly by way of an easement connecting to a public street, and shall include an appurtenant, attached garage which may not be separately conveyed. The boundaries of the Units are further described in Section 5.5.

3.36 **Unit Designation:** means the combination of letters, numbers and words which identify the designated Units.

3.37 **Unit Owner or Owner:** means the person owning a Unit in fee simple absolute individually or as co-owner in any real estate tenancy relationship recognized under the laws of the State of Montana. Each Unit has only one owner for any voting purposes described herein.

3.38 **Unit Ownership Act:** means and refers to the Montana Unit Ownership Act, Section 70-23-101, *et seq.*, MCA (2015), as amended.

ARTICLE IV - RELATIONSHIP TO COMMUNITY ASSOCIATION

4.1 **Membership in Community Association.** The Property is subject to the Gallatin River Farm Governing Documents. All Unit Owners automatically are members of the Community Association by virtue of their undivided interest in the Property, in addition to being members of the Association. The Association will represent the Unit Owners interest in the Community Association as specified in the Bylaws.

4.2 **Services Provided by Community Association.** The Community Association may provide various services to the Unit Owners. Such services may currently include, but are not limited to, roadway maintenance and snowplowing. Charges for these services are a component of the Community Association assessments assessed to the Association on behalf of each Unit Owner under the Gallatin River Farm CC&Rs.

ARTICLE V - REAL ESTATE

5.1 **Description.** The Property which is by this Declaration submitted and subject to the Unit Ownership Act is described on **Exhibit A** attached hereto.

5.1.1 The provisions of this Declaration and the Bylaws shall be construed to be covenants running with the land and shall include every Unit and shall be binding upon the Unit

Owners, their heirs, personal representatives, successors and assigns for as long as this Declaration and the Bylaws are in effect.

5.1.2 The Project consists of the Property and improvements currently existing and to be constructed thereon, including the Buildings, General Common Elements and Limited Common Elements, to be used for residential use and associated use, all as shown on the site plan and floor plans (the "Plans"). The Plans will accurately depict the Units and the Building layouts, as located (or to be located) on the Property, with the square footage, design and dimensions of each Unit. There will initially be one (1) Building situated on the Property, as shown on the site plan attached hereto as Exhibit C. Ultimately a total of five (5) Buildings are expected to be constructed after this Declaration is recorded, though Declarant has no obligation to construct all or any of such Buildings or submit them to this Declaration. Three (3) of the Buildings shall contain five (5) Units each and the remaining five (5) Units may be in one (1) Building or allocated among two (2) separate Buildings. There will also be General Common Elements as described herein for the use and benefit of all Unit Owners as well as Limited Common Elements described herein reserved for the use of a certain Unit or Building or number of Units or Buildings to the exclusion of the other Units or Buildings.

5.1.3 The Declarant may construct a Facility on the Common Elements that would be a building used to house the tanks and pumps for the fire suppression systems for the Buildings as well as provide a storage area for the use of the Association or Unit Owners and a covered gathering area.

5.2 **Condominium Units.** Each Unit shall be inseparable, and may be conveyed, leased, rented, devised or encumbered as a condominium in accordance with this Declaration. The Units include a proportional undivided interest in the Common Elements as provided in Section 8.1.

5.3 **Encroachments.** If any portion of the General Common Elements or Limited Common Elements encroaches upon a Unit or Units, a valid easement for the encroachment and for the maintenance of the same, so long as it stands, shall and does exist. If any portion of a Unit encroaches upon the General Common Elements or Limited Common Elements, or upon an adjoining Unit or Units, a valid easement for the encroachment and for the maintenance of the same, so long as it stands, shall and does exist. Such encroachments and easements shall not be considered or determined to be encumbrances either on the General Common Elements, the Limited Common Elements, or on the Units for the purpose of marketability of title. In the event a Building or any portion thereof is destroyed and then rebuilt, the Owners agree that minor encroachments of parts of the General Common Elements or Limited Common Elements because of such construction shall be permitted and that an easement for such encroachment and the maintenance and repair of the same shall and does exist.

5.4 **Buildings.** The Units comprising the condominium will be contained in multiple Buildings. Three (3) of the Buildings shall contain five (5) Units each and the remaining five (5) Units may be in one (1) Building or allocated among two (2) separate Buildings Units. Buildings may contain some Units that are one story and some that are two stories.

5.5 **Boundaries of Units.** Each Unit shall be bounded by the interior surfaces of its perimeter walls, floors, suspended ceilings, and trim. A Unit shall include all lath, furring, wallboard, plasterboard, plaster, paneling, tiles, paint, finished flooring, unfinished flooring of a garage, and any other materials constituting any part of its finished surfaces, including unit access door(s), so described. All other portions of the walls, floors, or ceilings shall be a part of the Common Elements. In addition, each Unit shall include the following: (a) all spaces, interior partitions, windows, window frames, interior doors, door frames, and all other fixtures and improvements within the boundaries of the Unit, and (b) all outlets of utility service lines, including, but not limited to, power, light, gas, hot and cold water, heating, refrigeration, air conditioning, and waste disposal within the boundaries of the Unit, but shall not include any part of such lines or ducts themselves. In interpreting deeds, mortgages, deeds of trust, and other instruments for any purpose whatsoever or in connection with any matter, the existing physical boundaries of the Unit or of a Unit reconstructed in substantial accordance with the original plans hereof shall be conclusively presumed to be the boundaries regardless of settling, rising, or lateral movement of the Building and regardless of variances between boundaries as shown on the plat and those of the actual Building or Buildings.

5.6 **Construction Materials.** The principal materials of construction of the Buildings are described on **Exhibit B** attached hereto.

ARTICLE VI - EASEMENTS

6.1 **Common Element Easements.** A perpetual, nonexclusive easement and right of ingress and egress and support through the General Common Elements is appurtenant to each Unit for the benefit of each Owner and all the General Common Elements are subject to such rights. Every Owner shall have the right to use and enjoy the Limited Common Elements appurtenant to such Owner's Unit. The foregoing easements and rights are subject to the limitations and restrictions set forth in this Declaration and the other Governing Documents.

6.2 **Plat Easements.** The Project is subject to all easements as shown and reserved on the Plat, including but not limited to ditch easements, stormwater pond easements, and fire pond and access easements.

6.3 **Trail System and Wildlife Easements.** Declarant hereby reserves unto itself and its designees a perpetual, non-exclusive easement upon, across, over, and under the General Common Elements (but specifically excluding any Buildings or other structures located on the Property) for the creation, use, and maintenance of trail systems, including, without limitation, pedestrian, bicycle, and for the creation, use, and maintenance of wildlife resistant landscape treatments and features, wildlife corridors, winter wildlife ranges, and natural wildlife habitats. Any person using this easement shall, as a condition of such use, indemnify and hold harmless Declarant, the Association, the Board and the Owners for any damage, injury or loss sustained as a result of such use. The exercise of this easement shall not unreasonably interfere with the use of any Unit or the General Common Elements. The reservation of this easement does not obligate the Declarant to construct or reserve the easement(s) described herein.

6.4 **Easement for Utilities Within Units.** Each Unit may have its air space penetrated by electrical wires and lines, gas lines, mechanical equipment, including air handling ducts, hot and cold-water lines, waste water lines and vents and other utility and mechanical lines

(including, but not limited to, power, telephone, television, internet and natural gas), pipes or equipment. These lines, pipes or equipment, where they serve only one (1) Unit shall be appurtenant to such Unit, but where they serve more than one (1) Unit shall be part of the General Common Elements. Such items shall be so installed and maintained so that they shall not unreasonably interfere with the use of the Unit air space by the Owners of the same and shall wherever possible be located in any space available between the actual ceiling and a dropped ceiling or within a wall. A non-exclusive easement shall exist through, over and across each Unit for structural support of the Unit and for the use, inspection, installation, maintenance, replacement and repair of such utility lines, pipes and mechanical equipment for the use of all of the Unit Owners or the Unit Owners being serviced by the air space being penetrated by such lines, pipes and/or equipment. After completion of construction of a Unit, an easement for ingress and egress for the purpose of such inspection, installation, maintenance, replacement or repair of such easement rights shall only be exercised under the direction and approval and with the authority of the Association and/or the Manager unless an emergency exists in which event any action may reasonably be taken which is justified under the circumstances to minimize damage or injury which would otherwise occur as a consequence of such emergency. There shall be easements to, through and over those portions of the land, structures, buildings, improvements and walls (including interior Unit walls) contained therein for the continuing maintenance and repair of all utilities in the Project. There shall exist easements of support with respect to any Unit interior wall that supports a Common Element. The foregoing easements are all permanently reserved to Declarant, the Association and the designees of each.

6.5 Easements for Public Utilities.

6.5.1 There are hereby reserved unto Declarant and granted to the Association, and the designees of each (which may include, without limitation, Gallatin County, Montana and any utility) access and maintenance easements upon, across, over, and under all the General Common Elements (provided that such access may not be across, over or under any Buildings or other structures or buildings) to the extent reasonably necessary for the purpose of installing, replacing, repairing, and maintaining security and similar systems, roads, walkways, bicycle pathways, lakes, ponds, wetlands, drainage systems, street lights, signage, and all utilities, including, but not limited to, water, sewer, meter boxes, telephone, gas, and electricity, and for the purpose of installing any of the foregoing within easements designated for such purposes on recorded plats of the Property. Declarant specifically reserves unto itself and grants to the Association the right to convey to the local water supplier, electric company, natural gas supplier, or communications systems supplier easements across the General Common Elements (provided that such easements may not be across, over or under any Buildings or other structures or buildings) for ingress, egress, installation, reading, replacing, repairing, and maintaining utility meters and boxes. The exercise of this easement shall not extend to permitting entry into any Unit, nor shall any utilities be installed or relocated on the Property, except as approved by Declarant, during the Declarant Control Period, and thereafter by the Board or as set forth in Section 6.9.

6.5.2 Should any entity furnishing a service covered by the general easement herein provided request a specific easement by separate recordable document, Declarant shall have the right to grant such easement over any portion of the Property without conflicting with the terms hereof.

6.6 **Declarant Right to Relocate and Add Roadways.** Declarant reserves unto itself and grants to the Association the right to relocate, modify, remove and add roads upon the Common Elements.

6.7 **Easements for Maintenance, Repair, and Replacement.** Declarant, the Association, the designees of any of the foregoing and all public or private utilities shall have such easements over, under, across and through the Property, including all Units and Common Elements, as may be necessary to exercise any rights or fulfill any responsibilities, including those of installation, maintenance, repair, reconstruction or replacement, which they or any of them are required or permitted to perform under this Declaration or the other Governing Documents. These easements include, without limitation, the right of Declarant and the Association to obtain access at all times to meters, controls, valves, pipes, conduits, and other Common Elements located within or to which access may be gained through any Unit or its appurtenant Limited Common Elements. Except in an emergency situation, such entry into a Unit shall only be during reasonable hours and after notice to the Unit Owner.

6.8 **Structural Easements.** Every portion of a Unit which contributes to the structural support of the Building, other Units or the Common Elements shall be burdened with an easement of structural support for the benefit of the Building, Common Elements and other Units.

6.9 **Signage and Mailbox Easements.** Declarant reserves unto itself and grants to the Association the right to install permanent or temporary signage upon the Common Elements for identification of the project, directional, traffic control, safety, or as otherwise determined in the sole discretion of the Declarant or the Association. Declarant also reserves unto itself and grants to the Association the right to install permanent cluster mailboxes upon the Common Elements for use by the Unit Owners.

6.10 **Additional Easements for Other Projects.** Declarant hereby reserves unto itself (with the right to designate or assign to others) the following easements in connection with any improvements, facilities or developments constructed or to be constructed by Declarant, its affiliates or its designees in connection with or for the benefit of Other Projects, whether or not such improvements, facilities or developments are made a part of the Project.

6.10.1 A perpetual, nonexclusive easement for installation, utilization, tapping, tying into, extending and enlarging all utility mains or facilities located in the Common Elements, including connections to water, storm and sanitary sewer mains or related facilities within the Property. Declarant, its affiliate, or its designee or assign, as applicable, will pay all cost of such installation, utilization, tapping, tying into, extending and enlarging, and to the extent possible, will restore all areas thereby disturbed to substantially their condition immediately prior to commencement of such activities. All expenses of maintenance, repair, replacement and resurfacing of such utility mains or facilities shall be shared by the Association and the owners of the Other Projects utilizing such utility mains or facilities on a proportionate and equitable basis based on the use of such utility mains or facilities.

6.10.2 A perpetual, nonexclusive easement located as determined by Declarant in, over and upon the Common Elements (but not over any Buildings or other buildings or

structures on the Property) and any roadways within the Property for the purposes of ingress and egress to and from the Other Projects. Declarant or its designee or assign exercising such easement right, as applicable, shall be responsible for any physical damage caused to the Units or the Common Elements as a result of vehicular traffic connected with the development of Other Projects by Declarant or its designee or assign. If the easement is exercised for permanent access to Other Projects and the Association maintains roadways used for such access, then the owners of such Other Projects shall enter into a reasonable agreement with the Association to share the cost of maintenance of any access roadway serving such Other Projects.

6.11 Specific Written Easements. Declarant may, in its sole discretion without the necessity of consent by any interested party, prepare and record a subsequent instrument to specifically define by legal description the easements created by or in accordance with this Article VI. Nothing in this paragraph shall be construed to give Declarant the right to create easements not otherwise created by or in accordance with this Article VI. The easements provided for in this Article VI shall in no way adversely affect any other recorded easement on the Property.

6.12 Emergency, Security and Maintenance Easement. Public safety and other appropriate persons designated by the Board shall have the right, but not the obligation, to enter upon the Property, including any Unit or Common Element, for emergency, security, and safety reasons, to perform maintenance pursuant to Article VII hereof or repair or reconstruction pursuant to Article XIII, and to inspect for the purpose of ensuring compliance with this Declaration and the other Governing Documents. This right may be exercised, without limitation, by policemen, firemen, ambulance personnel, security officers and similar emergency personnel in the performance of their duties. Except in an emergency situation, entry shall only be during reasonable hours and after notice to the Owner. This right of entry shall include the right of the Association or their designees to enter upon any Unit to cure any condition which may increase the possibility of a fire or other hazard in the event an Owner fails or refuses to cure the condition within a reasonable time after request. Owners shall leave a key in a lock box attached to the exterior of their Units (and provide access to the lockbox to the Association), or otherwise provide access in a manner reasonably acceptable to the Association, for access pursuant to this paragraph or pursuant to Section 6.7. In the event of the failure of such Unit Owner to provide such means of access, the Association may gain access in such manner as may be reasonable under the circumstances and shall not be liable to such Unit Owner for any necessary damage to the Unit and any Limited Common Elements appurtenant thereto caused thereby or for repair or replacement of any doors or windows damaged in gaining such access.

6.13 Amendment or Repeal. The easements and other rights reserved or granted to Declarant in this Article VI may not be modified, amended or repealed without Declarant's prior written consent. Any attempted or purported modification, amendment or repeal without Declarant's written consent shall be void and have no effect.

ARTICLE VII - MAINTENANCE AND UPKEEP

7.1 Maintenance by Association. The Association shall maintain and repair, or cause to be maintained and repaired, all Common Elements and all exterior and structural components of each Unit and Building, including roofs. Without limiting the generality of the foregoing, the Association shall be responsible for the upkeep, maintenance and repair of any

roadways within the Property, Driveways and walkways within the Property (including snow removal) and of all roofs, siding, chimneys, decks, porches and patios. Such maintenance and repair costs that are attributable to a particular Unit or Units may be assessed to the affected Unit(s), in the discretion of the Board, pursuant to Section 9.8.6.

7.2 **Maintenance by Unit Owners.** Each Owner shall, at such Owner's cost and expense, maintain and keep in good repair, and in a safe condition, such Owner's Unit. No Owner, through act or omission, shall impair the structural soundness or integrity of any Building or impair any easement on the Property.

ARTICLE VIII - OWNERSHIP AND FLOOR PLANS

8.1 **Ownership of Common Elements.** Each Unit Owner shall own a percentage of undivided interest in the Common Elements equal to such Unit Owner's Percentage of Interest set forth on Exhibit E attached hereto. Declarant may amend Exhibit E from time to time as construction of Units is completed after the date of recording of this Declaration, in connection with any future annexation of additional property and in connection with any increase or decrease in the number of Units within the Project. Declarant may make such amendments without the consent of any other person. Such Percentage of Interest represents each Unit Owner's ownership interest in the Common Elements, liability for Common Expenses, and the relative voting interest of each Unit Owner in all matters concerning the Association. Except as otherwise limited in this Declaration or any other Governing Documents, each Unit Owner shall have the right to use the Common Elements for all purposes incident to the use of and occupancy of such Owner's Unit, and such other incidental uses permitted by this Declaration, which rights shall be appurtenant to and run with the whole Unit.

8.2 **Floor Plans and Exhibits.** The floor plans of the Units currently intended to be constructed in the Project are attached hereto as Exhibit D. Declarant shall amend Exhibit D from time to time as construction of Units is completed after the date of recording of this Declaration to the extent required by the Unit Ownership Act and in connection with any future phases of the Project. Declarant may make such amendments without the consent of any other person.

8.3 **Exclusive Ownership.** Each Owner shall be entitled to exclusive ownership and possession of the Owner's Unit. Such Owners may use the General Common Elements and Limited Common Elements in accordance with this Declaration and the other Governing Documents for the purposes for which they are intended, so long as they do not hinder or encroach upon the lawful rights of other Unit Owners.

8.4 **Use.** The Units and Common Elements shall be occupied and used as follows:

8.4.1 The Units may be used for lawful residential purposes only.

8.4.2 Except as otherwise set forth in this Declaration, there shall be no obstruction of the Common Elements nor shall anything be stored in or on the Common Elements without the prior consent of the Association.

8.4.3 Nothing shall be done in any Unit or in, on or to the Common Elements which will impair the structural integrity of a Building or any Common Element or which would structurally change a Building or Common Element, except as is otherwise provided herein and in accordance with the Governing Documents.

8.4.4 Except as otherwise set forth in this Declaration or as approved by the Board or Declarant, nothing shall be altered or constructed in or removed from the Common Elements.

ARTICLE IX - MEMBERSHIP; BOARD; ASSOCIATION AND ASSESSMENTS

9.1 **Membership.** Each Owner shall automatically, upon becoming the Owner of a Unit, be a member of the Association and shall remain a member for the period of the Owner's ownership of the Unit. Membership in the Association may not be transferred separately from the fee simple title to a Unit. Upon becoming a Unit Owner the Owner shall furnish to the Association a copy of the recorded instrument vesting that person with the interest required to make such person a member of the Association. Each such member at the same time shall give a single name and address to which notices to such member may be sent, as well as an e-mail address and telephone number by which that person can be contacted. In the event of any change in the facts reported in the original written notice, including any change of ownership, the member shall give a new written notice to the Association containing all the information required to be contained in the original notice. As against any member of the Association, and any person claiming by, through, or under such member, the Association may, but shall not be obligated to, rely, for any and all purposes, on the information reflected in the most recent written notice furnished with respect to such member. In no event will the Association have any obligation to investigate into the address or contact information of any member.

9.2 **Joint Ownership; Joint and Several Liability.** If a Unit Owner's interest in a Unit is held by more than one person or entity (in tenancy in common, as joint tenants, or otherwise), the membership in the Association appurtenant to such Unit shall be shared by all such persons or entities in the same proportionate interest and by the same type of ownership as the Unit is held, subject to reasonable Board regulation and restrictions on voting, notices, and assessment obligations as set forth in the Bylaws or otherwise. All such persons and entities shall be jointly and severally obligated to perform the responsibilities of the specific Unit Owner under the Governing Documents, including, without limitation, payment of assessments and other amounts owed pursuant to the Governing Documents. The membership rights of a Unit Owner that is not a natural person may be exercised by any officer, director, partner, trustee, member, manager, or other individual designated from time to time in a written instrument describing and certifying the authority of such person provided to the Secretary of the Association. In a multiple interest owner situation, if more than one person seeks to exercise the vote, the voting privilege shall be suspended. Neither the Association nor Declarant shall have any obligation to confirm, as among such multiple interest owners, which of the persons has the right to exercise a vote. In the case where a Unit Owner is not a natural person, or where there are multiple owners of a Unit, written notice shall be provided to the Secretary of the Association stating which person has authority to act on behalf of the Unit Owner and include that person's name, mailing and physical address, telephone number and e-mail address. The Association may rely on such notice until such notice is updated by a Unit Owner.

9.3 **Function of Board.** It shall be the function of the Board to:

9.3.1 Adopt bylaws for the governance of the Association.

9.3.2 Make provisions for the general management, repairs and maintenance of the General Common Elements, Limited Common Elements, and any other provisions for the benefit of the Association.

9.3.3 Levy assessments as provided for in the Declaration, Bylaws and Unit Ownership Act.

9.3.4 Adopt and implement a policy for the affairs of the Project.

9.3.5 Enter into contracts to hire personnel for the management of the affairs of the Association and the maintenance and repair of the Common Elements.

9.3.6 Adopt Rules and Regulations pursuant to Section 12.7.

9.3.7 Enter into contracts and negotiate and accept easements for the benefit of the Association.

9.3.8 Acquire, operate and maintain equipment and facilities for the benefit of the Association, or enter into contracts regarding such operation and maintenance.

9.3.9 Operate and maintain any recreational facilities constructed on the General Common Elements.

9.3.10 Act as the power of attorney for each Owner with regard to representation within the Community Association.

9.3.11 Manage the affairs of, and take action for, the Association, except where the vote of the Owners or consent of Declarant is specifically required by the Governing Documents or applicable law.

9.4 **Function of Association.** It shall be the function of the Association to:

9.4.1 Elect the Board to the extent and as provided in the Bylaws.

9.4.2 Approve any changes to this Declaration, subject to the provisions of Article X.

9.5 **Vote.** Each Owner shall have voting rights as specified in the Bylaws.

9.6 **Failure to Comply - Attorney Fees.** Each Owner shall comply strictly with the provisions of this Declaration and the other Governing Documents, as the same may be amended, supplemented, restated or replaced from time to time. Failure to comply with any of the same shall be grounds for an action to recover sums due, for damages or injunctive relief or both, and for reimbursement of all costs, including attorney fees and costs incurred in connection therewith, which action shall be maintainable by the Board or the Manager in the name of the

Association, on behalf of the Owner or by an aggrieved Owner where there has been a failure of the Association to bring such action within a reasonable time.

9.7 Payment of Assessments.

9.7.1 Each Unit Owner, by acceptance of a deed or other document of conveyance, whether or not it is expressed in the deed or document, is deemed to covenant and agree to pay all assessments of and other amounts due to the Association and to waive any rights under Montana or Federal law to claim a homestead exemption for the assessments or such other amounts. Assessments shall be billed in such manner and on such dates as the Board may establish. Unless the Board otherwise provides, the assessment shall be due and payable in advance quarterly on the first day of each fiscal quarter. The amount of the assessment against each Unit shall be the personal and individual debt of the Owner thereof. No Owner may exempt himself, herself or itself from liability for assessments by waiver of the use or enjoyment of any of the Common Elements or by abandonment of such Owner's Unit. All assessments which are not paid when due and payable become delinquent and are subject to interest and late charges. The Board shall have the responsibility of taking prompt action to collect any unpaid assessment which becomes delinquent. In the event of delinquency in the payment of an assessment, the Unit Owner shall be obligated to pay interest at the rate to be determined by the Board or the maximum rate allowed by law, whichever is less, on the amount of the assessment from the due date thereof, together with such late charges as may be required by the Board. Suit to recover a money judgment for unpaid assessments may be maintainable without foreclosing or waiving the lien securing the same. If any Owner is delinquent in paying any assessments or other charges levied on such Owner's Unit, the Board may require any unpaid installments of all outstanding assessments to be paid in full immediately.

9.7.2 Common Expenses of the Association shall be charged to the Unit Owners on a uniform rate of assessment.

9.7.3 Limited Expenses shall be charged to the Unit Owners as set forth in Section 9.8.6.

9.8 Levying Assessments. The Board shall levy assessments upon the Unit Owners in the following manner and for the following reasons (all as determined by the Board):

9.8.1 All assessments shall be fixed by resolution of the Board. Notice of the assessment, whether regular or special, the amount thereof, and the purpose for which it is made, including an annual budget for expenditures and operation for regular annual assessments, shall be served on all Unit Owners affected by delivering a copy of the same to such Owners affected, by delivering a copy of the same to the Owner personally or by mailing a copy of the notice to the said Owners at their addresses of record at least thirty (30) days prior to the annual meeting of members of the Association.

9.8.2 Assessments shall be made for the repair, replacement, insurance, including, without limitation, insurance deductibles where applicable, general maintenance, repair and upkeep, management and administration of Common Elements and other common

expenses, fees, costs and expenses of the Manager, taxes for common areas, reserves for contingent liabilities and other related items.

9.8.3 Assessments may also be made for the creation of a reserve budget including reserves for items determined by the Board, which may include, among other items, a reserve for insurance deductibles. The Board may, in its discretion, levy an assessment in an amount sufficient to meet the projected reserve needs of the Association.

9.8.4 The Board shall have the authority to establish a multi-tiered system of assessments based upon the completion status of various Buildings. Declarant (and any affiliate of Declarant to which a Unit is conveyed) shall not pay any assessments on the Units it owns; provided, however, that Declarant may, in its sole discretion, subsidize or reimburse the Association for any expenses the Association incurs in connection with the Units Declarant owns, which are not covered by the assessment of other Unit Owners.

9.8.5 In addition to other authorized assessments, the Board may levy special assessments to cover unbudgeted expenses in excess of those budgeted. In no case may the amount of any special assessment levied on any Unit pursuant to this subparagraph exceed an amount equal to the total amount of the special assessment multiplied by the Percentage of Interest for any Unit. This subparagraph does not apply to special assessments for Limited Expenses which are provided for in the following subparagraph or to any assessments levied against a Unit Owner for the acts or omissions of that Unit Owner or its family members, invitees or guests, which may be levied against the applicable Unit Owner.

9.8.6 Assessments (regular or special) may also be made for the payment of Limited Common Element expenses such that the Unit Owners are chargeable only for the expenses relating to their respective Units and appurtenant Limited Common Elements, as determined by the Board. Unit Owners shall share in the payment for Limited Expenses for the repair, maintenance and replacement of Limited Common Elements benefitting their respective Units in proportion to the Percentage of Interest of such Unit Owners. If only one Unit is associated with the Limited Common Element involved, then, in the discretion of the Board, the entire cost of such repair, maintenance, reconstruction or replacement may be assessed to that Unit Owner.

9.8.7 Assessments may also be made for any purpose contemplated by this Declaration and for any purpose set out in the Unit Ownership Act, including, but not limited to, any special assessments that are not assessed on an annual basis. To the extent facilities or infrastructure serving the Project are not within, wholly or partially, the Property (for example, water detention facilities or storage ponds) and the Board determines that the Association is required to pay for or maintain and/or operate, or it is in the best interest of the Association to pay for or maintain and/or operate, such facilities or infrastructure the Association may levy assessments to cover the cost of such maintenance and/or operation.

9.8.8 In a voluntary conveyance of a Unit, the grantee of the Unit shall be jointly and severally liable with the grantor for all unpaid assessments by the Association against the grantor's Unit up to the time of the grant or conveyance, without prejudice to the grantee's right to recover from the grantor the amounts paid by the grantee therefore. However, any such

grantee shall be entitled to a statement from the Manager or Board, as the case may be, setting forth the amount of unpaid assessments against the grantor's Unit due the Association and such grantee shall not be liable for, nor shall the Unit conveyed be subject to a lien for, any unpaid assessments made by the Association against the grantor prior to the date of such statement in excess of the amount therein set forth.

9.8.9 At the time the Association creates its first budget, an account or accounts shall be set up to which initial assessments shall then be deposited.

9.9 Liens for Assessments.

9.9.1 The Association shall have a lien against each Unit to secure payment of delinquent assessments and other amounts payable hereunder attributable to that Unit, as well as interest, late charges (subject to the limitations of Montana law), and costs of collection (including attorney fees and costs). Such lien shall be superior to all other liens, except as set forth in § 70-23-607 of the Unit Ownership Act (including any amendment to the Unit Ownership Act which affords a higher priority to the lien of the Association). Such lien may be enforced by suit, judgment, and judicial or non-judicial foreclosure.

9.9.2 The Association may bid for the Unit at the foreclosure sale or other legal sale and acquire, hold, lease, mortgage, convey and otherwise deal with the Unit. While a Unit is owned by the Association following foreclosure: (a) no right to vote shall be exercised on its behalf; (b) no assessment shall be levied on it; and (c) each other Unit shall be charged, in addition to its usual assessment, its equal pro rata share of the assessment (based on Percentage of Interest) that would have been charged such Unit had it not been acquired by the Association. The Association may sue for unpaid assessments and costs without foreclosing or waiving the lien securing the same.

9.9.3 Subject to Section 9.10, the sale or transfer of any Unit shall not affect the assessment lien or relieve such Unit from the lien for any subsequent assessments.

9.9.4 The Board, on behalf of the Unit Owners, shall have the power to bid on the Unit at a foreclosure or other legal sale and to acquire and hold, lease, mortgage and vote the votes appurtenant to, convey or otherwise deal with the same. Any lienholder holding a lien on a Unit may pay, but shall not be required to pay, any unpaid assessments payable with respect to any such Unit, and upon such payment, such lienholder shall have a lien on the Unit for the amounts paid of the same rank as the lien of such lienholder's encumbrance without the necessity of having to file a notice or claim of such lien.

9.10 **Unpaid Assessments - Mortgagee.** Where a lienholder or other purchaser of a Unit obtains title to the Unit as a result of foreclosure of the first mortgage or trust indenture, such acquirer of title, his successors and assigns, shall not be liable for the share of assessments by the Association chargeable to such Unit which became due prior to the acquisition of title to such Unit by such acquirer. Such unpaid assessments shall be deemed to be Common Expenses collectable from all of the Units including such acquirer and such acquirer's successors and assigns.

9.11 **Assessments for Damages.** Damage to any part of a Unit resulting from maintenance, repair, emergency repair or replacement of any of the General Common Elements or Limited Common Elements or as a result of an emergency repair within another Unit at the instance of the Association (other than damage caused by a Unit Owner or a family member, guest or invitee thereof) shall be designated Common Expenses by the Association and assessed in accordance with such designation.

ARTICLE X - AMENDMENT, ANNEXATION AND WITHDRAWAL

10.1 **Amendment By Declarant.** During the Declarant Control Period, Declarant may unilaterally amend this Declaration for any purpose, provided the amendment has no material adverse effect on the right of any Owner (or the consent of any such Owner is obtained). Notwithstanding the above, During the Declarant Control Period, Declarant may unilaterally amend this Declaration if such amendment is (i) necessary to bring any provision in compliance with any applicable governmental statutes, necessary governmental registrations, rule, regulation, or judicial determination; (ii) necessary to enable any reputable title insurance company to issue title insurance coverage on the Units; (iii) required by an institutional or governmental lender or purchaser of mortgage loans, including, for example, the Federal National Mortgage Association or Federal Home Loan Mortgage Corporation, to enable such lender or purchaser to make or purchase mortgage loans on the Units; (iv) necessary to enable any governmental agency or reputable private insurance company to insure mortgage loans on the Units or to insure the Project or any portion thereof, including any individual Unit; (v) necessary to allow the Association to obtain insurance contemplated by this Declaration, including, without limitation, property or liability insurance, at a reasonable price and on reasonable terms; or (vi) otherwise necessary to satisfy the requirements of any governmental or quasi-governmental agency or to comply with the Gallatin River Farm Governing Documents. However, any such amendment shall not adversely affect the title to any Unit unless the Owner shall consent thereto in writing.

10.2 **Amendment By Owners.** After the Declarant Control Period, this Declaration may be amended by (a) the affirmative vote or written consent, or any combination thereof, of at least seventy-five percent (75%) of the total Percentage of Interest of the Association, and (b) during the Declarant Control Period, with the written consent of Declarant, which shall not be unreasonably withheld. However, any such amendment shall not adversely affect the title to any Unit unless the Owner shall consent thereto in writing.

10.3 **Amendment By Board.** In the alternative, the Board may adopt an amendment to this Declaration provided at least a majority of the members of the Board vote in favor of the adoption and, during the Declarant Control Period, the written consent of Declarant is obtained, which consent shall not be unreasonably withheld. However, any such amendment shall not adversely affect the title to any Unit unless the Owner shall consent thereto in writing.

10.4 **Restriction on Amendment.** Notwithstanding Section 10.2, the Percentage of Interest necessary to amend a specific clause pursuant to Section 10.2 shall not be less than the prescribed Percentage of Interest required for action to be taken under that clause. To be effective, any amendment must be recorded with the office of the Clerk and Recorder of Gallatin County, Montana. If an Owner consents to any amendment to this Declaration or the Bylaws, it will be conclusively presumed that such Owner has the authority to consent, and no contrary

provision in any mortgage or contract between the Owner and a third party will affect the validity of such amendment. No amendment may remove, revoke, or modify any right or privilege of the Declarant without the written consent of the Declarant.

10.5 Annexation. During the Declarant Control Period, Declarant may from time to time unilaterally (a) annex any other property within Annexable Property into the Project, and/or (b) add Units to the Project. Annexable Property is defined as property contained within the "Gallatin River Farm North Major Subdivision, Phase 2 – Final Plat" as filed in the office of the Clerk and Recorder of Gallatin County, Montana [Plat Reference: J-504]. Annexation of property and addition of Units shall be accomplished by filing a supplement to this Declaration with the office of the Clerk and Recorder of Gallatin County, Montana. Such supplement shall not require the consent of the Owners or the Board. The supplement shall include a revised Percentage of Interest Exhibit showing the percentage of undivided interest in the Common Elements for each Unit Owner and an updated site plan and floor plans to the extent required by the Unit Ownership Act.

10.6 Withdrawal. During the Declarant Control Period, Declarant may from time to time unilaterally amend this Declaration for the purpose of removing property then owned by Declarant or its affiliates from the coverage of this Declaration. Any property removed from this Declaration shall be subject to whatever easements, if any, are reasonably necessary for access to or operation of the Project and each of the Units. In addition, during the Declarant Control Period, Declarant may from time to time unilaterally amend this Declaration for purposes of decreasing the number of Units within the Project by removing certain Units from the coverage of this Declaration; provided that Declarant may make any such decrease only with respect to Units then owned by Declarant which have not been constructed. Any amendment pursuant to this Section 10.6 shall not require the consent of the Owners or the Board. Any amendment to remove one or more Units shall include a revised Percentage of Interest Exhibit showing the percentage of undivided interest in the Common Elements for each Unit Owner following the removal and an updated site plan to the extent required by the Unit Ownership Act.

10.7 Plat Amendment. Declarant may unilaterally amend the plat of the Property without the additional consent of any Owner or the Board; provided, however, that nothing in this paragraph allows Declarant to replat the property underlying a Building (*i.e.*, change a boundary line or platted easement under a Building) without the consent of the Owners of the Units in such Building.

10.8 Merger or Consolidation. During the Declarant Control Period, Declarant may merge or consolidate the Association with a property owners' association of the same form of ownership. Upon written request from Declarant during the Declarant Control Period, the Board and each Unit Owner shall execute such documents and take such actions as shall reasonably be requested by Declarant to approve and effect any such merger or consolidation.

10.9 Agreement Regarding Amendments. The Unit Owners, the Association, lien holders, mortgagees and all others acquiring any interest in or lien on the Units, the Common Elements or any other portion of the Project shall be bound by the rights of Declarant to amend and supplement this Declaration (and Bylaws if required) and the plat of the Property as set forth in this Declaration, including, without limitation, in connection with any annexation of Annexed

Property, removal of property from this Declaration, reduction or increase in the number of Units, completion of construction of Units and any change in the Percentage of Interest, site plan or floor plans in connection therewith, and their consent to such amendments and supplements is implied and agreed to by the acceptance or acquisition of any interest in or lien on the Units, the Common Elements or any other portion of the Project. Declarant is hereby appointed the Unit Owners', Association's, lien holders' and mortgagees' agent and attorney-in-fact to execute and record such amendments, supplements and related documents.

ARTICLE XI - ASSIGNMENT

Any or all of the rights and powers granted or reserved to Declarant in the Condominium Documents or by law, including the power to approve or disapprove any act, use or proposed action or any other matter or thing, may be assigned by Declarant to any other entity or to the Association. Any such assignment or transfer shall be made by appropriate instrument in writing duly recorded in the office of the Clerk and Recorder of Gallatin County, Montana.

ARTICLE XII - UNIT RESTRICTIONS

All of the Units shall be held, used and enjoyed subject to the Gallatin River Farm Governing Documents and the following limitations and restrictions:

12.1 **Use.** The Units shall be used only for residential occupancy by Unit Owners, their families, and their guests and invitees, consistent with the restrictions contained herein and in the other Governing Documents and may not be used for any other purposes whatsoever.

12.2 **Alterations and Modifications.** No Unit Owner shall make any alteration or modification of any Common Element. All additions, changes, alterations and other Construction Activity relating to a Unit shall be subject to the Design Guidelines and to review and approval of the Association and as applicable, the DRC. The Board may establish Rules and Regulations from time to time further governing additions, changes, alterations or other Construction Activity. Prior to commencement, a Unit Owner shall provide written notice to the Secretary of the Association of any additions, changes, alterations and other Construction Activity with respect to the Owner's Unit, which notice shall be provided prior to submitting any material to the DRC for review, if DRC review is required. The Unit Owner shall promptly notify the Secretary of the Association of any DRC approval or denial.

12.2.1 **Change in Unit Boundaries.** No change in the boundaries of existing Units shall encroach upon the boundaries of the Common Elements or other Units except by amendment to this Declaration and, during the Declarant Control Period, with the written approval of Declarant. Any such change will be set forth in an amendment showing the revised plans of the Unit(s) which amendment shall be approved, signed and acknowledged by the Association, the Owner(s) of the applicable Unit(s) and all lien holders and mortgagees of the Units concerned, to the extent required by the Unit Ownership Act. Boundary walls must be equal in quality of design and construction to the existing boundary walls.

12.2.2 **Load Bearing Walls.** Notwithstanding any rights to remodel the Units, load bearing walls may not be moved or structurally altered.

12.2.3 Liens for Alterations or Modifications. Labor performed and materials furnished and incorporated into a Unit with the consent of or at the request of the Unit Owner, or such Unit Owner's agent, contractor or subcontractor, may be the basis for the filing of a lien against the Unit or the Unit Owner consenting to or requesting the same. Each Unit Owner shall indemnify and hold harmless each of the other Owners against any lien against the Unit or against the General Common Elements or Limited Common Elements for construction performed or for labor, materials, services or other products incorporated in the Owner's Unit at such Owner's request.

12.3 **Activities.** No unlawful activity shall be carried on in any Unit or upon the Common Elements nor shall anything be done by a Unit Owner (or the family members, guests or invitees of a Unit Owner) which may be or become an annoyance or a nuisance to the Unit Owners. No unreasonably noisy activity shall occur in or on the Common Elements or in any Unit at any time, and disputes among Unit Owners, arising as a result of this provision which cannot be amicably resolved, shall be arbitrated by the Board. No Unit Owner shall do or permit anything to be done or keep or permit to be kept in such Owner's Unit or on the Common Elements anything that will increase the rate of insurance on the Project without the written approval of the Board, and each Unit Owner who causes such an increase shall pay to the Association the increased cost of insurance premiums resulting from any such activity or the maintenance of any such condition even if approved. Activities which are deemed offensive and are expressly prohibited include, but are not limited to, the following: any activity involving the use of firearms, fireworks, air rifles, pellet guns, B-B guns, bows and arrows, or other similar dangerous weapons, projectiles or devices.

12.4 **Animals.** No animals shall be kept, raised, or bred in any Unit. The grazing of cattle or sheep anywhere on the Property is not permitted. Notwithstanding the foregoing, a reasonable number of birds, dogs, cats, tortoises or other customary household pets may be kept in a Unit ("**Permitted Household Pets**"). Permitted Household Pets shall not be kept, bred or maintained for any commercial purpose, nor in unreasonable quantities nor in violation of any other provision of this Declaration. Chickens are not deemed Permitted Household Pets. No Permitted Household Pet shall be permitted to harass any wildlife. Permitted Household Pets are not to be kept outside of the Unit or temporarily chained up. Any Permitted Household Pet that is on the Property shall be accompanied by the Unit Owner, or their family member or guest, and kept under control at all times. Unit Owners are responsible for damage and waste caused by any Permitted Household Pet associated with a Unit. The Board may establish such other reasonable Rules and Regulations concerning Permitted Household Pets and other animals as it deems reasonable.

12.5 **Aesthetics.** The Common Elements (including Limited Common Elements appurtenant to the Units) shall not be used for storage of supplies, recreational equipment, materials, personal property or trash or refuse of any kind, except as provided in duly adopted Rules and Regulations. No unsightly conditions shall be maintained on the patio, porch or deck of any Unit or in any other area that is visible from the exterior of the Unit and only furniture and equipment consistent with the normal and reasonable use of such areas shall be permitted to remain there during seasons when such areas are reasonably in use and no furniture or equipment of any kind shall be stored thereon during seasons when such areas are not reasonably in use. The Board may adopt Rules and Regulations from time to time addressing the exterior

appearance of Units and Buildings and the use of porches, decks and patios, including, without limitation, installation and use of hot tubs and barbeque grills. Individual bear-proof trash receptacles are required to be used by the Unit Owners, if bear-proof trash receptacles are not provided and maintained by the Association in areas designated therefore at all times. In general, no activity shall be carried on nor condition maintained by a Unit Owner, either in a Unit or upon the Common Elements, which is detrimental to the appearance of the Project. By way of example, outdoor basketball hoops and plastic furniture are not permitted.

12.6 Advertising. No signs or other advertising devices of any kind shall be displayed which are visible from the exterior of a Unit or on the Common Elements, including, but not limited to, any real estate sign, "for rent" sign, political sign or the like, without written permission from the Board and, during the Declarant Control Period, the Declarant.

12.7 Rules and Regulations. It is intended that the Board may make, amend and repeal Rules and Regulations from time to time that apply to the Project, Facility, Unit Owners and their family members, guests and invitees. Such Rules and Regulations may govern use of the Common Elements and Units, the personal conduct of Unit Owners and their family members, guests and invitees, and may govern construction and design criteria and aesthetic standards so as to further the use, enjoyment and aesthetics of the Project for the Owners. Such Rules and Regulations may also establish enforcement mechanisms, including penalties for violation thereof. Following adoption, amendment or repeal of any Rules and Regulations the Board shall provide Unit Owners with notice thereof. Copies of all such Rules and Regulations and amendments thereto in effect from time to time shall be furnished to Unit Owners upon request. Notwithstanding anything to the contrary herein, the Board shall not adopt any rules or regulations that adversely affect the Declarant without Declarant's prior written consent.

12.8 Parking. No person may park vehicles on or along any road within the Property, except in areas specifically designated for parking. Likewise, no person may park in any Driveway or in front of any garage except that an Owner, or the Owner's family member, guest or invitee, may park in the Driveway or in front of the garage appurtenant to the Unit owned by such Owner, subject to the other provisions of this Declaration and any Rules and Regulations. All vehicles shall be parked in garages appurtenant to the Units, in Driveways appurtenant to the Units or in other designated parking spaces. No vehicles may be stored anywhere on the Property except in garages, Driveways and other parking areas designated by the Condominium Documents or by the Board. The Board may establish such other reasonable Rules and Regulations concerning parking as it deems reasonable.

12.9 Marijuana. No part of the Property may be used for the consumption, growing of, storage of, sale, dispensing, or other transfer of marijuana (medical or recreational) for any purpose, including, but not limited to, marijuana which is consumed, grown, harvested, and distributed pursuant to any law that authorizes or licenses any of the foregoing activities.

12.10 Lights. Except as otherwise regulated in the Gallatin River Farm CC&Rs or the Design Guidelines, the Board may adopt Rules and Regulations regulating exterior lighting or seasonal or holiday lighting.

12.11 **Handicapped Rights.** Subject to the review rights of the Association or DRC and applicable law, each Owner shall have the right to modify his Improvements and the route to his Unit (as applicable and necessary) leading to the entrance of his Improvements, at his sole cost and expense, in order to facilitate access by Persons who are blind, visually handicapped, deaf or physically disabled, or to alter conditions which could be hazardous to such Persons.

12.12 **Reserved Rights of Declarant.** None of the restrictions contained in this Article XII shall apply to the activities or signs or billboards, if any, of Declarant during the development and sales period or of the Association in furtherance of its powers and purposes set forth herein, as the same may be amended from time to time. Notwithstanding anything to the contrary elsewhere herein, Declarant, its affiliates and their respective agents, contractors and employees involved in the development of the Project shall have the right to maintain a sales office, a business office, a construction office, model Units, storage areas (for vehicles, machinery, equipment and material used or to be used in connection with the development work, sales and marketing) and reasonable parking incident to the foregoing and such access to, from and over the Project as may be reasonable to enable development and sale of the entire Project by Declarant (including, without limitation, development of the Buildings, Units and recreational facilities, if any, in any phase of the Project) and may continue to do so during the entire development and sales period. In addition, Declarant reserves the right to change the type of construction, size, layout, location, architectural design and principal construction materials of Buildings and the Units therein; provided, however, that any Buildings and the Units therein shall be generally consistent with the quality of construction of Buildings and Units described in this Declaration.

ARTICLE XIII - INSURANCE

13.1 **Association Policies.** All insurance policies upon the Common Elements and the Units shall be purchased by the Association and shall be insured by an insurance company authorized to do business in Montana.

13.1.1 **Named Insured – Association Insurance.** The named insured under all policies purchased by the Association shall be the Association individually as agent for the Unit Owners. However, the property insurance maintained by the Association shall include, where so required, each Unit Owner and their lenders or mortgagees as additional insureds as their interests may appear, with standard mortgagee clause in favor of each listed mortgagee, subject however, to loss payment and other provisions as are set forth by these documents. Such property insurance policies shall provide that payments for losses thereunder by the insurer shall be paid to the Insurance Trustee hereinafter designated, and all policies and endorsements thereon shall be deposited with the Insurance Trustee.

13.1.2 **Copies to Owners.** Upon written request by a Unit Owner, the Association shall furnish one copy of each insurance policy and of all endorsements to such Unit Owner. The Association shall also provide, upon written request, certificates of insurance evidencing property and liability insurance to each Unit Owner and/or their lender/mortgagee where required.

13.2 **Coverage.** The Association shall obtain and continue in effect the following types of insurance, if reasonably available, or if not reasonably available, the most nearly equivalent coverages as are reasonably available (as determined by the Board):

13.2.1 Property Insurance: All Units and Buildings, including the Common Elements and such portions of the Units as are for insurance purposes normally deemed to constitute part of the Common Elements and such other improvements to land as may be included in the Common Elements and where such improvements are reasonably insurable under a property policy, shall be fully insured to an amount equal to the full replacement cost thereof with all such insurance to be based on current replacement cost value, as determined annually by the Board, but subject to such deductible clauses as are required in order to obtain and maintain coverage at reasonable costs, and which coverage shall be increased by the Board as may be necessary to provide that the insurance proceeds will be sufficient to cover replacement, repairs or reconstruction. Such coverage for the Units shall be determined by the Board; however, the initial scope of coverage under the Association's property damage insurance policy will be what is commonly referred to as "bare walls," so that such insurance policy excludes all personal property within the Unit or Limited Common Elements, and floor, wall and ceiling coverings, electric fixtures, appliances, water heaters, water filters, built-in cabinets and countertops, and window treatments, including curtains, drapes, blinds, hardware, and similar window treatment components, betterments and improvements made by the Owners or replacements of any of the foregoing.

13.2.2 Workers Compensation. Workers compensation as required by law and employer's liability insurance with respect to officers and employees of the Association, if applicable.

13.2.3 Director's and Officer's Liability. Unless otherwise determined by the Board, a directors and officers liability insurance policy with a limit of not less than \$1,000,000 (or such higher limit as may be determined by the Board) to insure against liability for actions taken by individuals in their capacity as officers or directors of the Association.

13.2.4 General Liability. Commercial general liability insurance on an occurrence form covering bodily injury, including death, and property damage with a limit of not less than \$1,000,000 per occurrence and \$2,000,000 in the aggregate and including coverage for personal injury, products and completed operations and contractual liability. Such insurance shall cover and indemnify the Association, the Board, the Manager, if any, and each director, officer and employee of the foregoing against liability for all tort claims arising out of or relating to the Association's ownership, operation, use and maintenance of the Project; and such policy may include, where available, the Unit Owners as additional insureds; provided, however, that such insurance is not intended to contribute to or be in lieu of any individual Unit Owner's liability policies required to be carried by each Unit Owner as stipulated below and under which each Unit Owner's liability insurance shall be primary for each respective Unit Owner.

13.2.5 Umbrella/Excess Liability. Umbrella/excess liability insurance providing coverage in excess of the underlying commercial general liability and auto liability policies with a limit of not less than \$5,000,000 per occurrence and in the aggregate, or such other amounts as may be determined by the Board.

13.2.6 Fidelity Bond. Fidelity and crime insurance with a limit of \$1,000,000 or such other limit as may be determined by the Board, covering officers and employees of the Association who handle or are responsible for its funds.

13.2.7 Other Insurance. Such other insurance as the Board shall determine from time to time to be desirable and as may be required by the Federal and State laws.

13.2.8 Insurance Changes. If the Board determines that the Association's property insurance should be changed from its current coverage, due to cost or otherwise, the Board may amend this Declaration to reduce or increase the Association's obligation to maintain such insurance and to require each Unit Owner to maintain property insurance on such Unit Owner's Unit for the difference in coverage. Such amendment may include such additional requirements and limitations relating to such insurance as the Board deems reasonable and may include provisions addressing use of insurance proceeds and repair or reconstruction in the event damage to or destruction of a Unit. The Board may cause such amendment to be prepared and recorded without the consent of the Unit Owners; provided, however, notice shall be provided to each Unit Owner a reasonable time, not to be less than forty-five (45) days, in advance of such change in order to allow each Unit Owner the ability to obtain such newly required property insurance.

13.3 **Premiums and Deductibles**. Premiums upon insurance policies obtained by the Association shall be paid by the Association as a Common Expense, except that the amount of increase in the premium that is directly related to increased insured value relating to a Unit Owner's alteration, betterment or improvement or that is incurred or occasioned by the negligence, willful misconduct, occupancy, or abandonment of a Unit or its appurtenances or of the Common Elements by a Unit Owner (or a Unit Owner's family, invitees or guests) shall be assessed against that Owner. Not less than ten (10) days prior to the date when a premium is due, evidence of such payment shall be furnished by the Association to each lienholder listed in the roster of lienholders if requested in writing by such lienholder. In the event of an insured loss, the amount of any deductible paid in connection therewith shall, in the discretion of the Board, either (a) be treated in the same manner as the premiums for the applicable coverage, (b) be assessed to one or more Unit Owners as such loss circumstances may equitably warrant, or (c) be assessed to a specific Unit Owner if the loss resulted from the negligence or willful misconduct of a Unit Owner (or a Unit Owner's family, invitees or guests).

13.4 **Insurance Trustee**. The Board shall have the exclusive authority to make a claim and adjust a loss under policies purchased by the Association. Upon such election being made by the Board, the Board shall provide that all proceeds covering property losses shall be paid to such bank in Montana with trust powers as may be designated as insurance trustee by the Board, which trustee is herein referred to as the "Insurance Trustee." The Insurance Trustee shall not be liable for payment of premiums nor for the renewal or the sufficiency of policies nor for the failure to collect any insurance proceeds. The duty of the Insurance Trustee shall be to receive such proceeds as are paid and hold the same in trust for the purposes elsewhere stated in this Declaration and for the benefit of the Unit Owners and their mortgagees in the following shares, but which shares need not be set forth in the records of the Insurance Trustee.

13.4.1 Unit Owners. Where all Units are destroyed, an undivided share for each Unit Owner, such share being the same as the Percentage of Interest appurtenant to each Unit. In the event less than all Units are damaged or destroyed, then such proceeds shall be held only for the Owner(s) of the damaged or destroyed Unit(s) to the extent of the repair costs of the damage or in the event of destruction, to the extent of the fair market value of the Unit before the destruction. In the event Common Elements are damaged or destroyed, then the proceeds with respect to such Common Elements shall be held for the Owners in accordance with their interests in such Common Elements.

13.4.2 Mortgagees. In the event a mortgagee endorsement has been issued as to a Unit, the share of the Unit Owner shall be held in trust for the mortgagee and the Unit Owner as their interests may appear; provided, however, that no mortgagee shall have any right to determine or participate in the determination as to whether or not any damaged property shall be reconstructed or repaired, and no mortgagee shall have any right to apply or have applied to the reduction of a mortgage debt any insurance proceeds except distributions thereof made to a Unit Owner and mortgagee pursuant to the provisions of this Declaration.

13.5 **Unit Owners' Insurance**. Each Unit Owner shall procure and maintain, and shall provide the Board upon request with a certificates of insurance showing that the Unit Owner has in full force and effect (provided that the Board shall have no obligation to request such certificates or to monitor Unit Owner insurance, and none of the Association, the Board or Declarant shall have any liability with respect thereto), the insurance itemized below, which shall be maintained on a primary basis, and the cost of which shall be the sole and exclusive responsibility of the Unit Owner:

13.5.1 Property insurance for the Unit that provides coverage for what is not covered by the policy maintained by the Association as referenced in Section 13.2.1 above.

13.5.2 Liability insurance on an occurrence form against claims for bodily injury, death or property damage occurring on, in or about the Unit and insuring the Unit Owner's liability with a limit of not less than \$1,000,000.

Each Unit Owner shall have the right to carry other insurance for such Unit Owner's own benefit. All policies carried by the Unit Owners (a) shall contain waivers of subrogation of claims against the Association, its officers and directors; and (b) shall not adversely affect or diminish any liability under any insurance obtained by the Association. Each Unit Owner may seek to add Deductible Assessment coverage to their personal insurance policy form HO-6, where available and at the sole cost of such Unit Owner, to cover those potential Association deductibles which may be assessed to any one or more Unit Owner.

13.6 **Distribution of Proceeds**. Proceeds of insurance policies received by the Insurance Trustee shall be distributed to or for the benefit of the beneficial Owners in the following manner:

13.6.1 Miscellaneous. Expenses of administration, Insurance Trustee and construction or remodeling supervision shall be considered as part of the cost of construction, replacement or repair.

13.6.2 Reconstruction or Repair. Any balance remaining shall be used for reconstruction and repair as hereafter provided.

13.6.3 Partial Reconstruction. If the Unit or Units or Common Elements are destroyed and partially rebuilt, distribution shall be made to Unit Owners or the Insurance Trustee as their interests appear based on the reconstruction of the Units and Common Elements.

13.6.4 No Reconstruction or Repair. If there is no reconstruction or repair, the first proceeds for distribution after paying the Insurance Trustee shall be made to the first lienholders for such Units before distribution to the Unit Owners.

13.6.5 Remaining Proceeds. After distribution of the insurance proceeds as set forth above, any remaining proceeds shall be distributed to the Units Owner(s) as such Owner(s) interest shall appear. In the event less than all Units are damaged or destroyed, then such proceeds shall be held only for the Owner(s) of the damaged or destroyed Unit(s) to the extent of the repair costs of the damage or in the event of destruction, to the extent of the fair market value of the Unit before the destruction. To the extent Common Elements are damaged or destroyed then remaining proceeds shall be held for the Owners in accordance with their interests in such Common Elements.

13.6.6 Certificate. In making distribution to Unit Owners and their lienholders, the Insurance Trustee may rely upon a certificate of the Association made by the Board or Manager as to the names of the Unit Owners and their respective shares of the distribution.

13.7 **Board as Agent**. The Board is irrevocably appointed agent for each Unit Owner and for each owner of a mortgage or other lien upon a Unit and for each owner of any other interest in the Project to adjust all claims arising under insurance policies purchased by the Association and to execute and deliver releases upon the payment of claims.

13.8 **Benefit to Mortgagees**. Certain provisions in this Article XIII are for the benefit of mortgagees or trust indenture beneficiaries, and all such provisions are covenants for the benefit of any mortgagee or trust indenture beneficiary of a Unit and may be enforced by such mortgagee or beneficiary.

13.9 **Notice to Lienholder**. The Unit Owners, and not the Board nor the Association, shall notify the holder of any first lien on any of the Units of the occurrence of any loss in excess of \$10,000.00 within thirty (30) days of such loss.

13.10 **Reconstruction**.

13.10.1 Repair after Casualty. If any part of the Project shall be damaged by casualty, whether or not it shall be reconstructed or repaired shall be determined in the following manner:

13.10.1.1 *Lesser Damage*. If a Unit or Units (or other damaged property within the Project) is found by the Board to be tenantable after the casualty, the damaged property shall be repaired.

13.10.1.2. *Greater Damage.* If a Unit or Units (or other damaged property within the Project) is found by the Board to be not tenantable after the casualty, the damaged property may be reconstructed or rebuilt as provided in the applicable provisions of the Unit Ownership Act. If the decision is made not to rebuild then the property shall be subject to the applicable provisions of the Unit Ownership Act.

13.10.1.3. *Election not to Rebuild.* If a Unit or Units (or other damaged property within the Project) is found by the Board to be not tenantable after the casualty and the Association elects not to rebuild as herein provided and set forth in 70-23-803, MCA, and less than all of the Units have been damaged or destroyed, following any payments required by 70-23-805, MCA, the Insurance Trustee shall be instructed to disburse the proceeds in accordance with paragraph 13.6.4 and 13.6.5.

13.10.1.4. *Certificate.* The Insurance Trustee may rely upon a certificate of the Association made by the Board or Manager to determine whether or not the damaged property is to be reconstructed or rebuilt.

13.10.2 Plans and Specifications. Any reconstruction or repair must be substantially in accordance with the plans and specifications for the original improvements, or if not, then according to plans and specifications approved by not less than seventy-five percent (75%) of the aggregate Percentage of Interest of the Unit Owners, including the Owners of all Units the plans for which are to be altered, and in accordance with the review and approval requirements set forth in the Design Guidelines. Any such reconstruction not in accordance with the original plans and specifications must be set forth in an amendment to the Declaration. Provided that any consents required by the Governing Documents in connection with reconstruction not in accordance with the original plans and specifications have been obtained, the Board may cause to such amendment to be prepared and recorded without the consent of the Unit Owners.

13.10.3 Responsibility. The responsibility for reconstruction or repair after casualty shall be that of the Association which shall work with the Insurance Trustee to carry out the provisions of this Article XIII.

13.10.4 Assessments. If the proceeds of insurance are not sufficient to defray the estimated costs of reconstruction or repair for which the Association is responsible, or if at any time during such reconstruction or repair, or upon completion of such reconstruction or repair, the funds for the payment of the costs thereof are insufficient, assessments shall be made against all Unit Owners in sufficient amounts to provide funds to cover the payment of such costs. Such assessments shall be in proportion to the Owner's Percentage of Interest, unless such reconstruction or repair resulted from the negligence or willful misconduct of an Owner or the family member, guest or invitee of an Owner, in which case such amounts may, in the discretion of the Board, be assessed against such Owner.

13.10.5 Construction Funds. The funds for payment of costs of reconstruction or repair after casualty, which shall consist of proceeds of insurance held by the Insurance Trustee and funds collected by the Association from assessments against Unit Owners,

shall be disbursed in the sound discretion of the Insurance Trustee and according to the contract of reconstruction or repair, which contract must have the approval of the Board.

13.10.6 Surplus. It shall be presumed that the first monies disbursed in payment of costs of reconstruction and repair shall be from the insurance proceeds. If there is a balance in a construction fund after payment of all costs of the reconstruction and repair for which the fund is established, such balance shall be paid to the Association for the use and benefit of the Unit Owners.

13.11 Condemnation.

13.11.1 In the event the Common Elements, or any portion thereof, shall be taken for any public or quasi-public use, under any statute, by right of eminent domain or by purchase in lieu thereof, each Owner will be entitled to notice thereof, but the Association (acting through the Board) will act as attorney-in-fact for all Owners in the proceedings incident to such taking unless otherwise prohibited by law. The award for such taking will be payable to the Association as trustee for all of the Owners to be used as follows:

13.11.1.1. If the taking involves a portion of the Common Elements on which improvements (not including a Unit) have been constructed, then, unless (a) restoration or replacement of such improvements would be illegal under any applicable law, rule, regulation or ordinance or (b) within sixty (60) days after such taking (i) during the Declarant Control Period, Declarant elects not to restore or replace such improvements, or (ii) after the Declarant Control Period, the Board elects not to restore or replace such improvements, the Association shall restore or replace such improvements so taken on the Common Elements to the extent lands are available therefore, in accordance with plans approved by the DRB and, to the extent required by applicable law, any governmental or quasi-governmental entity having jurisdiction over the Property. If such improvements are to be restored or replaced, and the award for the taking is insufficient to restore or replace such improvements, the Board shall levy a special assessment, payable by the Unit Owners in accordance with their Percentage of Interest, in the aggregate amount of such deficiency and shall proceed to restore or replace such improvements.

13.11.1.2. If the taking does not involve any Common Elements including improvements, or if there is a decision made not to restore or replace as set forth above, or if there are net funds remaining after any such restoration or replacement of improvements is completed, then the Association shall retain such excess proceeds and place them in the Association's reserve account.

13.11.2 In the event any Unit or any portion thereof shall be taken, the condemnation award for such taking shall be paid solely to the Unit Owner(s) of such Unit(s). If an entire Unit shall be condemned, the Unit Owner thereof shall automatically cease to be an Owner or a member of the Association with respect to such Unit, but obligations arising prior to such taking shall remain the obligation of such person or entity regardless of the termination of membership.

ARTICLE XIV - MORTGAGEE PROVISIONS

12.1 **Notice of Action.** The following provisions are for the benefit of holders, insurers and guarantors of first mortgages on Units in the Project. The provisions of this Article apply to both the Declaration and to the Bylaws, notwithstanding any other provisions contained herein.

12.1.1 Any holder, insurer, or guarantor of a mortgage which provides a written request as specified herein to the Association's registered agent, thereby becoming an "**Eligible Holder,**" will be entitled to written notice of:

12.1.1.1 Any condemnation loss or any casualty loss of which the Association has notice which affects a material portion of the Project or which affects any Unit on which there is a first mortgage held, insured, or guaranteed by such Eligible Holder; or

12.1.1.2 Any delinquency in the payment of any assessment, charge, fine, penalty or other amount payable by an Owner subject to the mortgage of such Eligible Holder, where such delinquency has continued for a period of sixty (60) days, or any other violation of the Governing Documents relating to such Unit or the Owner which is not cured within sixty (60) days; or

12.1.1.3 Any lapse, cancellation, or material modifications of any insurance policy maintained by the Association.

12.1.2 The written request as required under this **Section 12.1** shall clearly state the legal description and address of the Unit as well as the name, mailing address, telephone number and e-mail address of the person who should receive the notices for the above listed actions. It is the sole obligation of the Eligible Holder to keep this information up to date with the Association and deliver notice as provided herein to the Association when this information changes. The Association will not be in default for failure to provide the above-listed notices if the Eligible Holder does not provide the Association with accurate information.

12.1.3 Any written notice required under this **Section 12.1** to be provided by the Association to an Eligible Holder shall be in writing and shall be deemed to have been duly given if delivered personally or if sent by certified mail, first-class, postage pre-paid, return receipt requested to the address provided by the Eligible Holder.

12.2 **Payment of Unpaid Assessment.** Any mortgagee or other lienholder holding a lien on a Unit may pay any unpaid Assessment with respect to such Unit, together with any and all costs and expenses incurred with respect to the Assessment lien securing such unpaid Assessment.

ARTICLE XV - REMOVAL OR PARTITION - SUBDIVISION

The Project may only be removed from condominium ownership, and may only be partitioned or sold, with the consent of Declarant (during the Declarant Control Period) and upon compliance with each of the conditions hereof:

15.1 The Board must approve the plans of removal, partition or sale, except for the rights reserved to Declarant pursuant to Article X. Such approval shall include the details of how any partition or sale, and the distribution of property or funds, shall be accomplished.

15.2 The plan of removal, partition, subdivision, abandonment, termination or sale must be approved as provided in the Unit Ownership Act. If approval for any of the forgoing is not required by the Unit Ownership Act, then approval shall be required from Owners representing at least seventy-five percent (75%) of the Percentage of Interest and any related first lienholder in the Project. Upon obtaining such approval, the Board shall be empowered to implement and carry out the plan of removal, partition, subdivision, abandonment, termination or sale. This provision is subject to the rights reserved to Declarant pursuant to Article X.

15.3 No Unit may be divided or subdivided into a smaller Unit, nor any portion thereof sold or otherwise transferred, except as provided above. No Units may be aggregated without the consent of Declarant.

15.4 The Common Elements shall not be abandoned, partitioned, subdivided, encumbered, or sold or transferred (except to the Association) without compliance with all of the above requirements.

ARTICLE XVI - INTERPRETATION

16.1 **Liberal Construction.** The provisions of this Declaration and of the Bylaws shall be liberally construed to effectuate the purposes of this Declaration and Bylaws and to create Buildings subject to and under the provisions of the Unit Ownership Act.

16.2 **Interpretation of Condominium Documents.** The Association, by and through its Board, shall have the exclusive right to construe and interpret the provisions of this Declaration and the other Condominium Documents. In the absence of any adjudication to the contrary by a court of competent jurisdiction, the Board's construction or interpretation shall be final, conclusive and binding as to all persons and property benefitted or bound by the covenants and the provisions hereof.

ARTICLE XVII - REMEDIES

All remedies provided for in this Declaration and the other Condominium Documents shall not be exclusive of any other remedies which may now be, or are hereafter, available to the parties hereto as provided for by law.

ARTICLE XVIII - SEVERABILITY

The provisions hereof shall be deemed independent and severable and the invalidity or partial invalidity or unenforceability of any one or more provision or any portion thereof shall not affect the validity or enforceability of the remainder of such provision or of any other provision hereof.

ARTICLE XIX - MISCELLANEOUS

19.1 **Utilities.** All Units shall be connected to community sewer service provided by Countryside Estates Subdivision Sewer District, or its successors or assigns, per the "Agreement

to Accept River Farm North Subdivision Phase II into the Countryside Estates Subdivision Sewer System” recorded in the office of the Gallatin County Clerk and Recorder Montana on April 1, 2011 at Document No. 2385522. All Owners shall be obligated to pay the required sewer fees for those services and for any other utility service provided to the Unit. Failure to pay fees to the utility providers may result in services being cut-off.

19.2 **Expenditures.** With the exception of expenditures required for emergency situations, no single expenditure or debt in excess of Ten Thousand Dollars (\$10,000.00) may be made or incurred by the Association without the prior approval of the Board. The limitation on single expenditures may be modified by the Board without amendment to this Declaration.

19.3 **Benefit.** Except as otherwise provided herein, this Declaration shall be binding upon and shall inure to the benefit of Declarant, the Association and each Unit Owner, and the heirs, estates, personal representatives, successors and assigns of each.

19.4 **Service of Process.** The name and address of the person to receive service of process for the Association until another designation is filed of record shall be the registered agent for the Association on file with the Montana Secretary of State.

19.5 **Notice to Lienholder.** A first lienholder, upon request, will be entitled to written notification from the Board of any default in the performance by an individual Unit Owner of any obligation under the Condominium Documents which is not cured within sixty (60) days.

19.6 **Right to Examine Books.** Every Unit Owner and first lienholder shall have the right, at the expense of such Unit Owner or first lienholder, to examine the books and records of the Association and of any Manager for the Project which relate to expenditures by the Association by giving a written notice requesting such examination. Upon receipt of such notice, the party receiving the notice shall schedule a mutually agreeable date and time during normal business hours for the examination, which date shall be not more than ten (10) days following the receipt of the notice requesting the examination.

19.7 **Warranties.** Declarant does not make any, and hereby expressly disclaims all, warranties or representations concerning the Property, the Units, the Buildings, the Declaration, the Bylaws or deeds of conveyance except as specifically set forth therein and no one may rely upon such warranty or representation not so specifically expressed therein. Estimates of Common Expenses and Limited Expenses are deemed accurate, but no warranty or guarantee is made or is intended, nor may one be relied upon.

19.8 **Notices.** All writings required or permitted to be given or delivered under this Declaration shall be deemed to have been given or delivered when deposited in the United States mail, postage prepaid, or by delivering it personally to an officer of the Association or Declarant or directly to a Unit Owner.

19.9 **Sale Disclosures.** At any time that Declarant or any other person owns a majority of the Units, Declarant or such other person shall provide to any purchaser the disclosure required by Montana Code Annotated § 70-23-613.

19.10 **Gender.** Whenever any reference herein is made to one gender, the same shall include a reference to any and all genders where the same would be appropriate; similarly, whenever a reference is made herein to the singular, a reference shall also be included to the plural where the same would be appropriate and vice versa.

19.11 **Conflicts.** In the event that there is any conflict or inconsistency between or among the provisions of Montana law, this Declaration, the Articles, the Bylaws and the Rules and Regulations, the provisions of Montana law, this Declaration, the Articles, the Bylaws and the Rules and Regulations (in that order) shall prevail.

19.12 **Limitation on Liability.** Notwithstanding anything to the contrary contained in this Declaration, any liability or claims against Declarant shall, except in connection with any express written warranty of Declarant, be strictly limited to Declarant's then-existing interest in the Property, and in no event shall any recovery or judgment be sought against any of Declarant's other assets (if any) or against any of Declarant's or its affiliates' owners, managers, members or partners (or their constituent members or partners) or any manager, director, officer, employee or shareholder of any of the foregoing. Further, in no event shall any claimant be entitled to seek or obtain any special, consequential, indirect, treble (or other multiplier) or punitive damages.

[Remainder of page intentionally left blank]

IN WITNESS WHEREOF, Declarant has caused this Declaration to be made and executed according to the provisions of the Montana Unit Ownership Act, Section 70-23-101, et seq., MCA 2015.

DECLARANT

FHG Construction, Inc.,
a Montana corporation

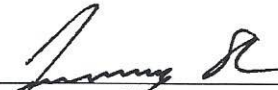
By: 
Name: Jeremy Shea
Title: President

STATE of MONTANA)
 :SS.
County of Gallatin)

On this 14th day of September, 2017, before me, a Notary Public in and for said State, personally appeared Jeremy Shea as the President for **FHG Construction, Inc.** and acknowledged to me that he executed the same on behalf of the corporation pursuant to the power and authority vested in him.

IN WITNESS WHEREOF, I have hereunto set my hand and affixed my Notarial seal the day and year written above.

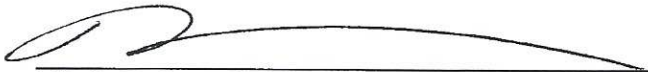

Mindy T. Cummings
Notary Public for the State of Montana
Residing at Gallatin Gateway, Montana
My Commission Expires: October 12, 2020

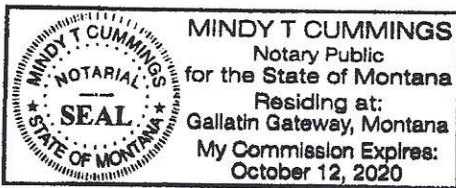

EXHIBIT A

Description of Property

The following described real property located in Gallatin County, Montana:

Lot 4 of Gallatin River Farm North Major Subdivision Phase 2 – Final Plat, Gallatin County, Montana, according to the official plat thereof on file and of record in the office of the County Clerk and Recorder, Gallatin County, Montana [Plat Reference J-504].

EXHIBIT B

Construction Materials

The principal materials of which the initial Building containing five (5) Units will be constructed are as follows:

- Wood frame construction with cement board siding
- Concrete foundation and concrete slab foundation, patios, and sidewalks
- Concrete walls
- Asphalt shingle roof with metal accents
- The decks will be made of a non-combustible material (ie., steel balconies)

EXHIBIT C

Site Plan

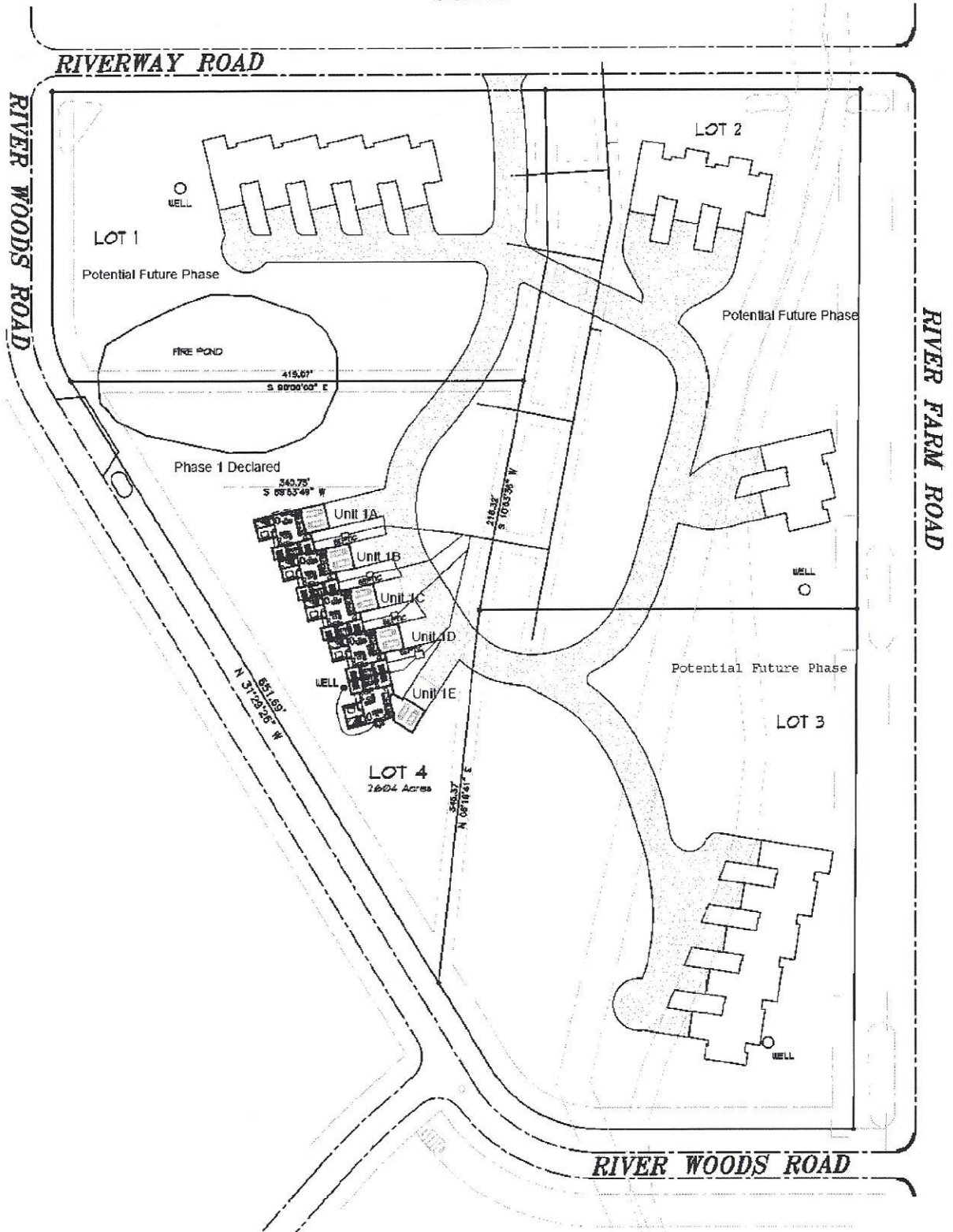

EXHIBIT D

Floor Plans and Certificate of Floor Plans

[see attached surveyed site plan and floor plans – 8 Pages (8½ X 11)]

The undersigned, being a duly registered professional architect in the State of Montana, herewith certifies the following:

That the surveyed site plan and floor plans for the Units on Lot 4 of the Croft Farms Condominiums, attached to this Exhibit D of the Declaration for Croft Farms Condominiums, fully and accurately depict the layout, location, Unit designation and dimensions of the Units currently under construction. Upon completion, an amendment certifying that these Units of the Croft Farms Condominiums were built will be recorded.

Dated: Oct. 27 2017

Mark A. Chandler
PLS, PE



Check applicable box: Registered Architect
 Registered Professional Engineer
 Registered Professional Land Surveyor

Number: 9518ES

LEGAL DESCRIPTION

LOT 4, GALLATIN RIVER FARM NORTH MAJOR SUBDIVISION, PHASE 2 [PLAT J-504], NE 1/4, SEC. 9, T. 1 S., R. 4 E. OF P.M.M., GALLATIN COUNTY, MONTANA
 ADDRESS: 91, 93, 95, 97, 99 CROFT FARMS ROAD, BELGRADE, MT 59714

ALL UNITS SHOWN HEREON WERE UNDER CONSTRUCTION ON DATE OF FIELD SURVEY (9/28/2017). CROFT FARMS ROAD AND DRIVEWAYS WERE UNDER CONSTRUCTION ON DATE OF FIELD SURVEY (9/28/2017).

SITE PLAN

CROFT FARMS CONDOMINIUMS

NOTES:
 UNIT AREAS SHOWN ON THE FLOOR PLANS ARE MEASURED TO THE EXTERIOR SURFACE OF THE STUD WALLS ON EXTERIOR WALLS, AND TO THE CENTERLINE OF COMMON WALLS. INTERIOR STAIRWAYS ARE INCLUDED IN THE FLOOR AREA OF THE LOWER LEVEL ONLY. THIS IS DONE TO MATCH THE ASSESSOR'S OFFICE FLOOR AREAS AS THEY CALCULATE THEM. THE ACTUAL UNIT BOUNDARIES ARE AS DEFINED IN THE DECLARATION OF THIS CONDOMINIUM.

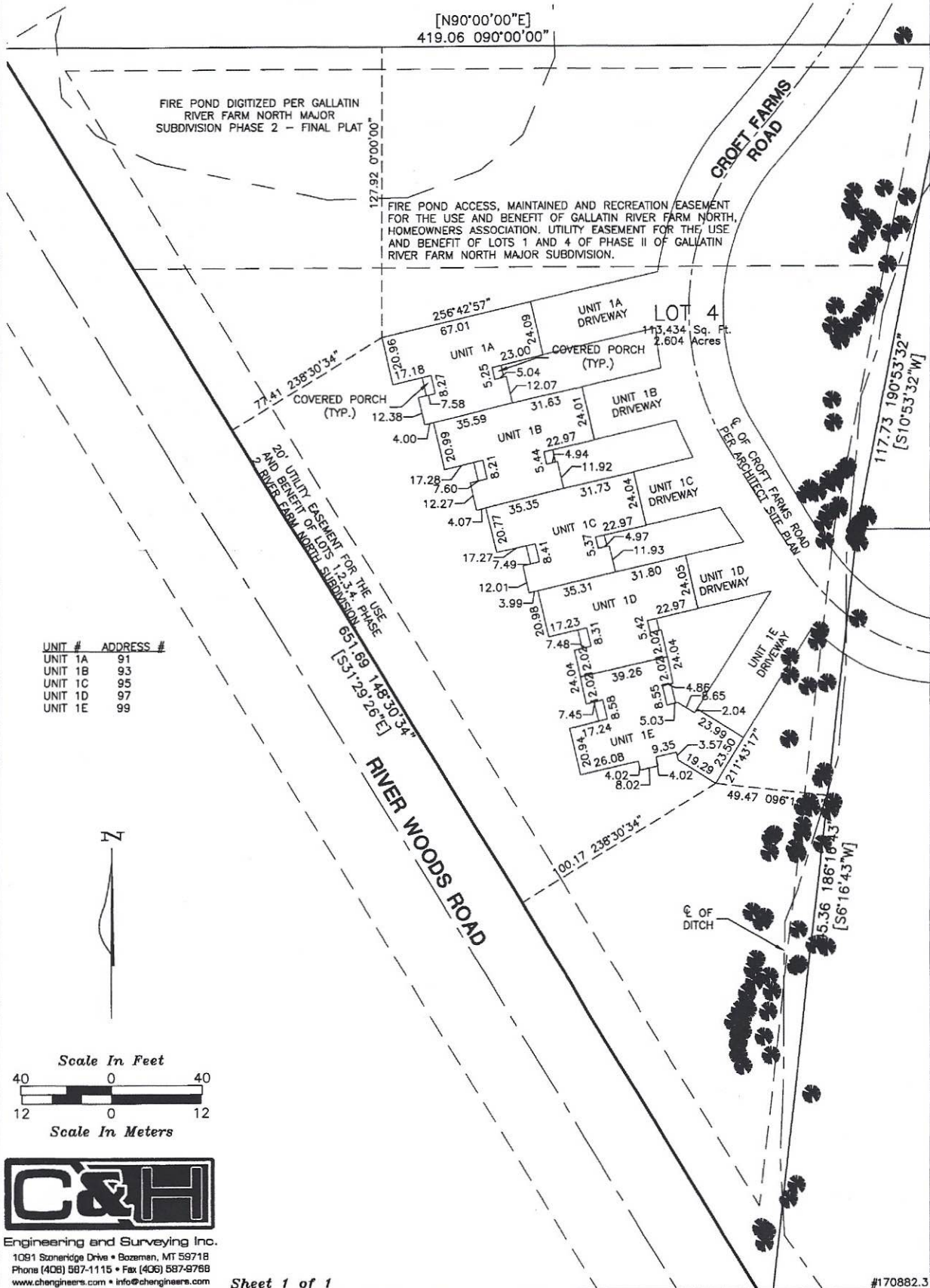

UNIT #	ADDRESS #
UNIT 1A	91
UNIT 1B	93
UNIT 1C	95
UNIT 1D	97
UNIT 1E	99

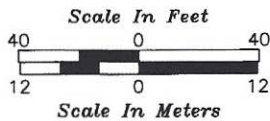

Engineering and Surveying Inc.
 1091 Stoneridge Drive • Bozeman, MT 59718
 Phone (406) 587-1115 • Fax (406) 587-9768
 www.chengineers.com • info@chengineers.com

LEGAL DESCRIPTION

LOT 4, GALLATIN RIVER FARM NORTH MAJOR
 SUBDIVISION, PHASE 2 [PLAT J-504], NE 1/4,
 SEC. 9, T. 1 S., R. 4 E. OF P.M.M., GALLATIN
 COUNTY, MONTANA

FIRST FLOOR PLAN
UNIT 1A
CROFT FARMS CONDOMINIUMS

AREA UNIT 1A

FIRST FLOOR	1,610 SF
GARAGE	548 SF
SECOND FLOOR	N/A
TOTAL	2,158 SF

NOTES:

UNIT AREAS SHOWN ON THE FLOOR PLANS
 ARE MEASURED TO THE EXTERIOR
 SURFACE OF THE STUD WALLS ON
 EXTERIOR WALLS, AND TO THE CENTERLINE
 OF COMMON WALLS. INTERIOR STAIRWAYS
 ARE INCLUDED IN THE FLOOR AREA OF
 THE LOWER LEVEL ONLY. THIS IS DONE
 TO MATCH THE ASSESSOR'S OFFICE FLOOR
 AREAS AS THEY CALCULATE THEM. THE
 ACTUAL UNIT BOUNDARIES ARE AS DEFINED
 IN THE DECLARATION OF THIS
 CONDOMINIUM.

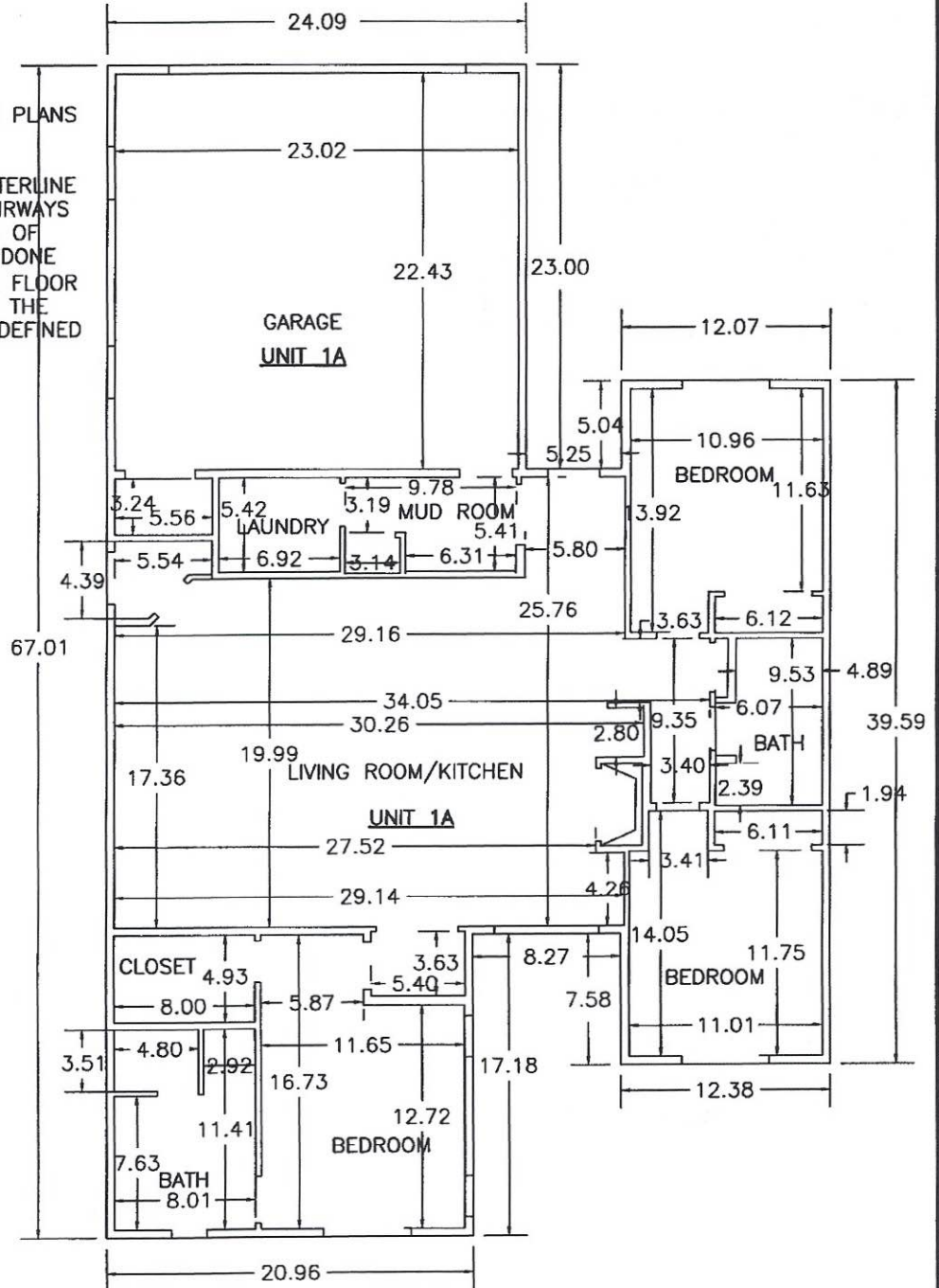

Scale In Feet

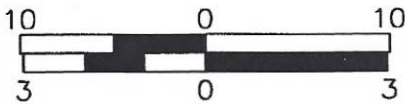

Scale In Meters



Engineering and Surveying Inc.

1091 Stoneridge Drive • Bozeman, MT 59718

Phone (406) 587-1115 • Fax (406) 587-9768

www.chengineers.com • info@chengineers.com

LEGAL DESCRIPTION

LOT 4, GALLATIN RIVER FARM NORTH MAJOR
 SUBDIVISION, PHASE 2 [PLAT J-504], NE 1/4,
 SEC. 9, T. 1 S., R. 4 E. OF P.M.M., GALLATIN
 COUNTY, MONTANA

FIRST FLOOR PLAN
UNIT 1B
CROFT FARMS CONDOMINIUMS

AREA UNIT 1B

FIRST FLOOR	1,610 SF
GARAGE	548 SF
SECOND FLOOR	460 SF
TOTAL	2,618 SF

NOTES:

UNIT AREAS SHOWN ON THE FLOOR PLANS ARE MEASURED TO THE EXTERIOR SURFACE OF THE STUD WALLS ON EXTERIOR WALLS, AND TO THE CENTERLINE OF COMMON WALLS. INTERIOR STAIRWAYS ARE INCLUDED IN THE FLOOR AREA OF THE LOWER LEVEL ONLY. THIS IS DONE TO MATCH THE ASSESSOR'S OFFICE FLOOR AREAS AS THEY CALCULATE THEM. THE ACTUAL UNIT BOUNDARIES ARE AS DEFINED IN THE DECLARATION OF THIS CONDOMINIUM.

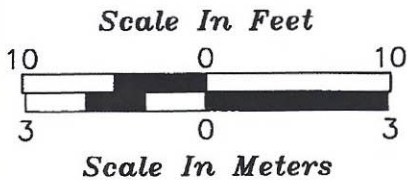
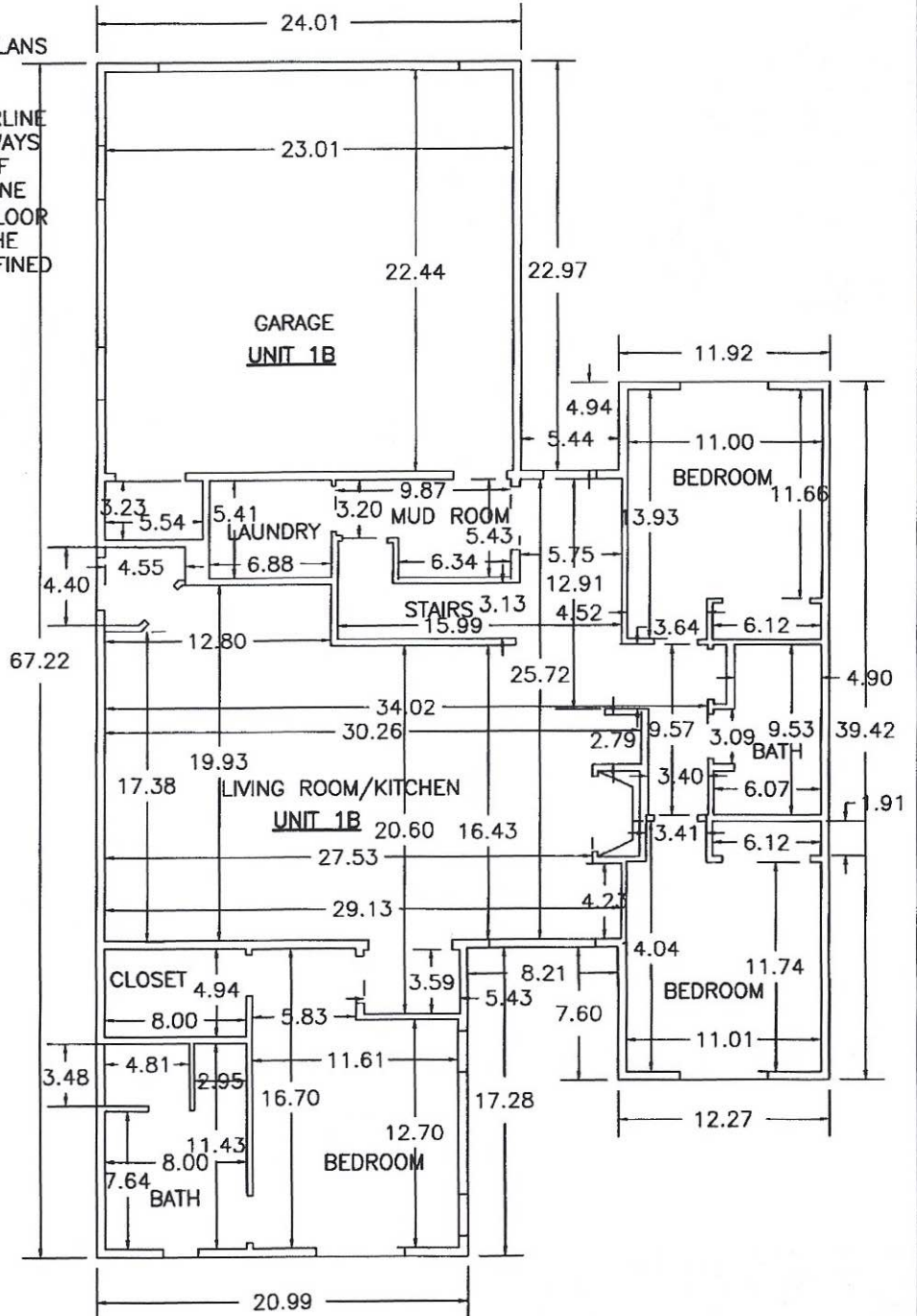

Engineering and Surveying Inc.
 1091 Stoneridge Drive • Bozeman, MT 59718
 Phone (406) 587-1115 • Fax (406) 587-9768
 www.chengineers.com • info@chengineers.com

LEGAL DESCRIPTION

LOT 4, GALLATIN RIVER FARM NORTH MAJOR
 SUBDIVISION, PHASE 2 [PLAT J-504], NE 1/4,
 SEC. 9, T. 1 S., R. 4 E. OF P.M.M., GALLATIN
 COUNTY, MONTANA

SECOND FLOOR PLAN

UNIT 1B

CROFT FARMS CONDOMINIUMS

AREA UNIT 1B

FIRST FLOOR	1,610 SF
GARAGE	548 SF
SECOND FLOOR	460 SF
TOTAL	2,618 SF

NOTES:

UNIT AREAS SHOWN ON THE FLOOR PLANS ARE MEASURED TO THE EXTERIOR SURFACE OF THE STUD WALLS ON EXTERIOR WALLS, AND TO THE CENTERLINE OF COMMON WALLS. INTERIOR STAIRWAYS ARE INCLUDED IN THE FLOOR AREA OF THE LOWER LEVEL ONLY. THIS IS DONE TO MATCH THE ASSESSOR'S OFFICE FLOOR AREAS AS THEY CALCULATE THEM. THE ACTUAL UNIT BOUNDARIES ARE AS DEFINED IN THE DECLARATION OF THIS CONDOMINIUM.

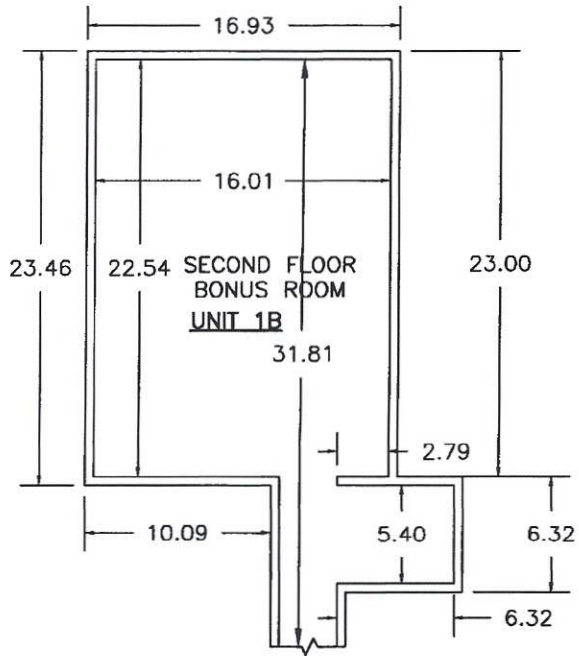

Scale In Feet

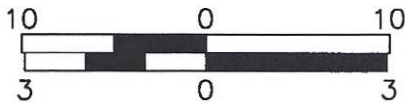

Scale In Meters



Engineering and Surveying Inc.

1091 Stoneridge Drive • Bozeman, MT 59718
 Phone (406) 587-1115 • Fax (406) 587-9768
 www.chengineers.com • info@chengineers.com

LEGAL DESCRIPTION

LOT 4, GALLATIN RIVER FARM NORTH MAJOR
 SUBDIVISION, PHASE 2 [PLAT J-504], NE 1/4,
 SEC. 9, T. 1 S., R. 4 E. OF P.M.M., GALLATIN
 COUNTY, MONTANA

FIRST FLOOR PLAN
UNIT 1C
CROFT FARMS CONDOMINIUMS

AREA UNIT 1C

FIRST FLOOR	1,610 SF
GARAGE	548 SF
SECOND FLOOR	N/A
TOTAL	2,158 SF

NOTES:

UNIT AREAS SHOWN ON THE FLOOR PLANS
 ARE MEASURED TO THE EXTERIOR SURFACE
 OF THE STUD WALLS ON EXTERIOR WALLS,
 AND TO THE CENTERLINE OF COMMON WALLS.
 INTERIOR STAIRWAYS ARE INCLUDED IN THE
 FLOOR AREA OF THE LOWER LEVEL ONLY.
 THIS IS DONE TO MATCH THE ASSESSOR'S
 OFFICE FLOOR AREAS AS THEY CALCULATE
 THEM. THE ACTUAL UNIT BOUNDARIES ARE
 AS DEFINED IN THE DECLARATION OF THIS
 CONDOMINIUM.

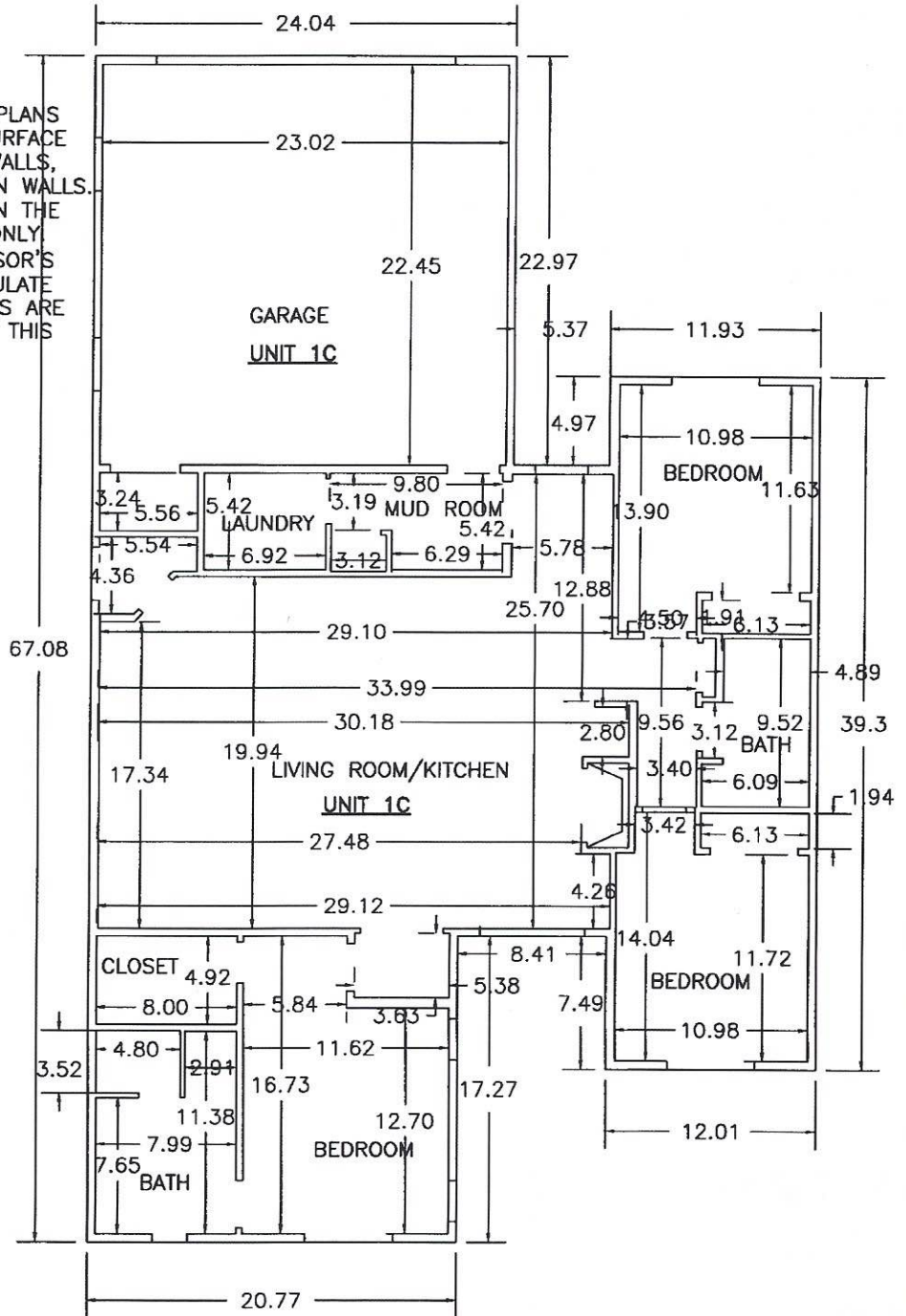

Scale In Feet

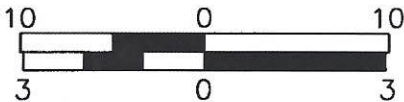

Scale In Meters



Engineering and Surveying Inc.

1091 Stoneridge Drive • Bozeman, MT 59718
 Phone (406) 587-1115 • Fax (406) 587-9768
 www.chengineers.com • info@chengineers.com

LEGAL DESCRIPTION

LOT 4, GALLATIN RIVER FARM NORTH MAJOR
 SUBDIVISION, PHASE 2 [PLAT J-504], NE 1/4,
 SEC. 9, T. 1 S., R. 4 E. OF P.M.M., GALLATIN
 COUNTY, MONTANA

FIRST FLOOR PLAN
UNIT 1D
CROFT FARMS CONDOMINIUMS

AREA UNIT 1D

FIRST FLOOR	1,610 SF
GARAGE	548 SF
SECOND FLOOR	460 SF
TOTAL	2,618 SF

NOTES:

UNIT AREAS SHOWN ON THE FLOOR PLANS ARE MEASURED TO THE EXTERIOR SURFACE OF THE STUD WALLS ON EXTERIOR WALLS, AND TO THE CENTERLINE OF COMMON WALLS. INTERIOR STAIRWAYS ARE INCLUDED IN THE FLOOR AREA OF THE LOWER LEVEL ONLY. THIS IS DONE TO MATCH THE ASSESSOR'S OFFICE FLOOR AREAS AS THEY CALCULATE THEM. THE ACTUAL UNIT BOUNDARIES ARE AS DEFINED IN THE DECLARATION OF THIS CONDOMINIUM.

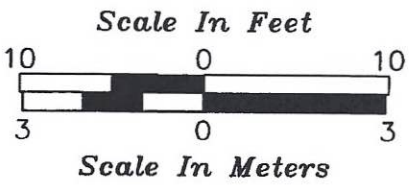
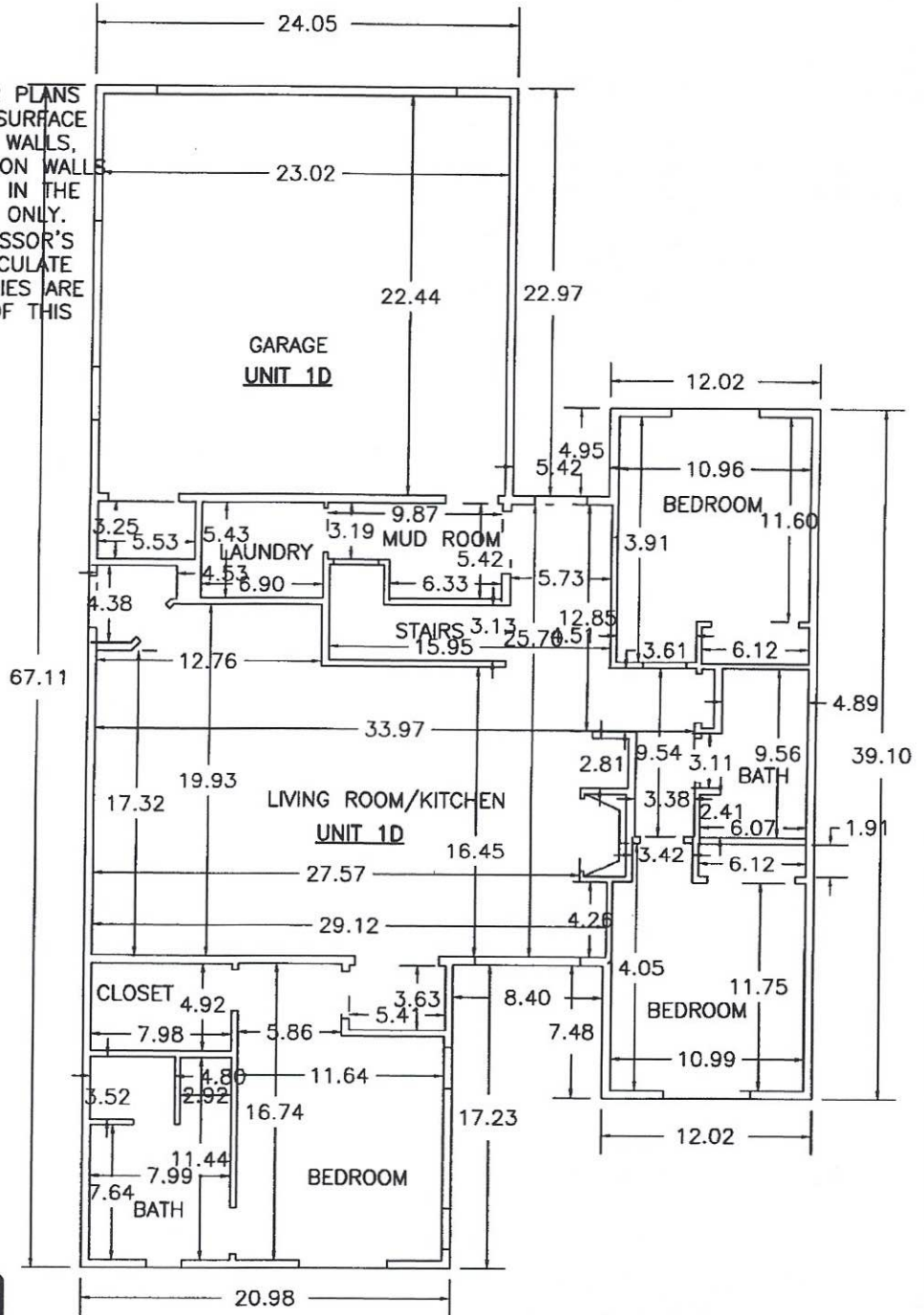

Engineering and Surveying Inc.
 1091 Stoneridge Drive • Bozeman, MT 59718
 Phone (406) 587-1115 • Fax (406) 587-9768
 www.chengineers.com • info@chengineers.com

LEGAL DESCRIPTION

LOT 4, GALLATIN RIVER FARM NORTH MAJOR
 SUBDIVISION, PHASE 2 [PLAT J-504], NE 1/4,
 SEC. 9, T. 1 S., R. 4 E. OF P.M.M., GALLATIN
 COUNTY, MONTANA

SECOND FLOOR PLAN

UNIT 1D

CROFT FARMS CONDOMINIUMS

AREA UNIT 1D

FIRST FLOOR	1,610 SF
GARAGE	548 SF
SECOND FLOOR	460 SF
TOTAL	2,618 SF

NOTES:

UNIT AREAS SHOWN ON THE FLOOR PLANS
 ARE MEASURED TO THE EXTERIOR SURFACE
 OF THE STUD WALLS ON EXTERIOR WALLS,
 AND TO THE CENTERLINE OF COMMON WALLS.
 INTERIOR STAIRWAYS ARE INCLUDED IN THE
 FLOOR AREA OF THE LOWER LEVEL ONLY.
 THIS IS DONE TO MATCH THE ASSESSOR'S
 OFFICE FLOOR AREAS AS THEY CALCULATE
 THEM. THE ACTUAL UNIT BOUNDARIES ARE
 AS DEFINED IN THE DECLARATION OF THIS
 CONDOMINIUM.

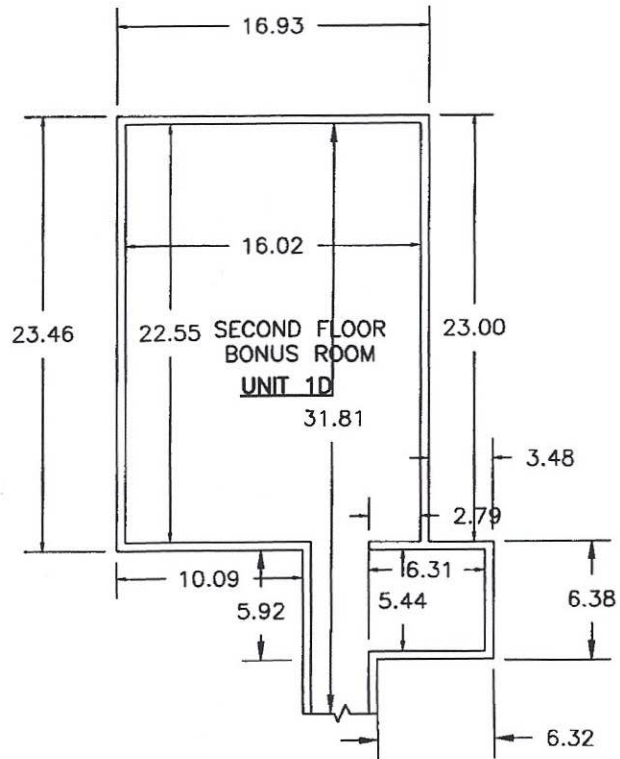

Scale In Feet

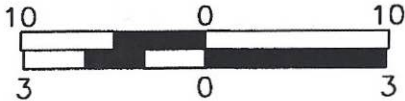

Scale In Meters



Engineering and Surveying Inc.

1091 Stoneridge Drive • Bozeman, MT 59718
 Phone (406) 587-1115 • Fax (406) 587-9788
 www.chengineers.com • info@chengineers.com

LEGAL DESCRIPTION

LOT 4, GALLATIN RIVER FARM NORTH MAJOR
 SUBDIVISION, PHASE 2 [PLAT J-504], NE 1/4,
 SEC. 9, T. 1 S., R. 4 E. OF P.M.M., GALLATIN
 COUNTY, MONTANA

FIRST FLOOR PLAN
UNIT 1E
CROFT FARMS CONDOMINIUMS

AREA UNIT 1E

FIRST FLOOR	1,603 SF
GARAGE	660 SF
SECOND FLOOR	N/A
TOTAL	2,263 SF

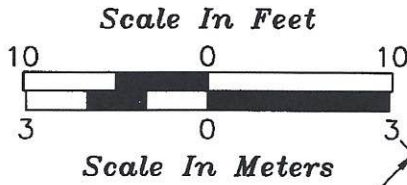

NOTES:
 UNIT AREAS SHOWN ON THE FLOOR PLANS
 ARE MEASURED TO THE EXTERIOR SURFACE
 OF THE STUD WALLS ON EXTERIOR WALLS,
 AND TO THE CENTERLINE OF COMMON WALLS.
 INTERIOR STAIRWAYS ARE INCLUDED IN THE
 FLOOR AREA OF THE LOWER LEVEL ONLY.
 THIS IS DONE TO MATCH THE ASSESSOR'S
 OFFICE FLOOR AREAS AS THEY CALCULATE
 THEM. THE ACTUAL UNIT BOUNDARIES ARE
 AS DEFINED IN THE DECLARATION OF THIS
 CONDOMINIUM.

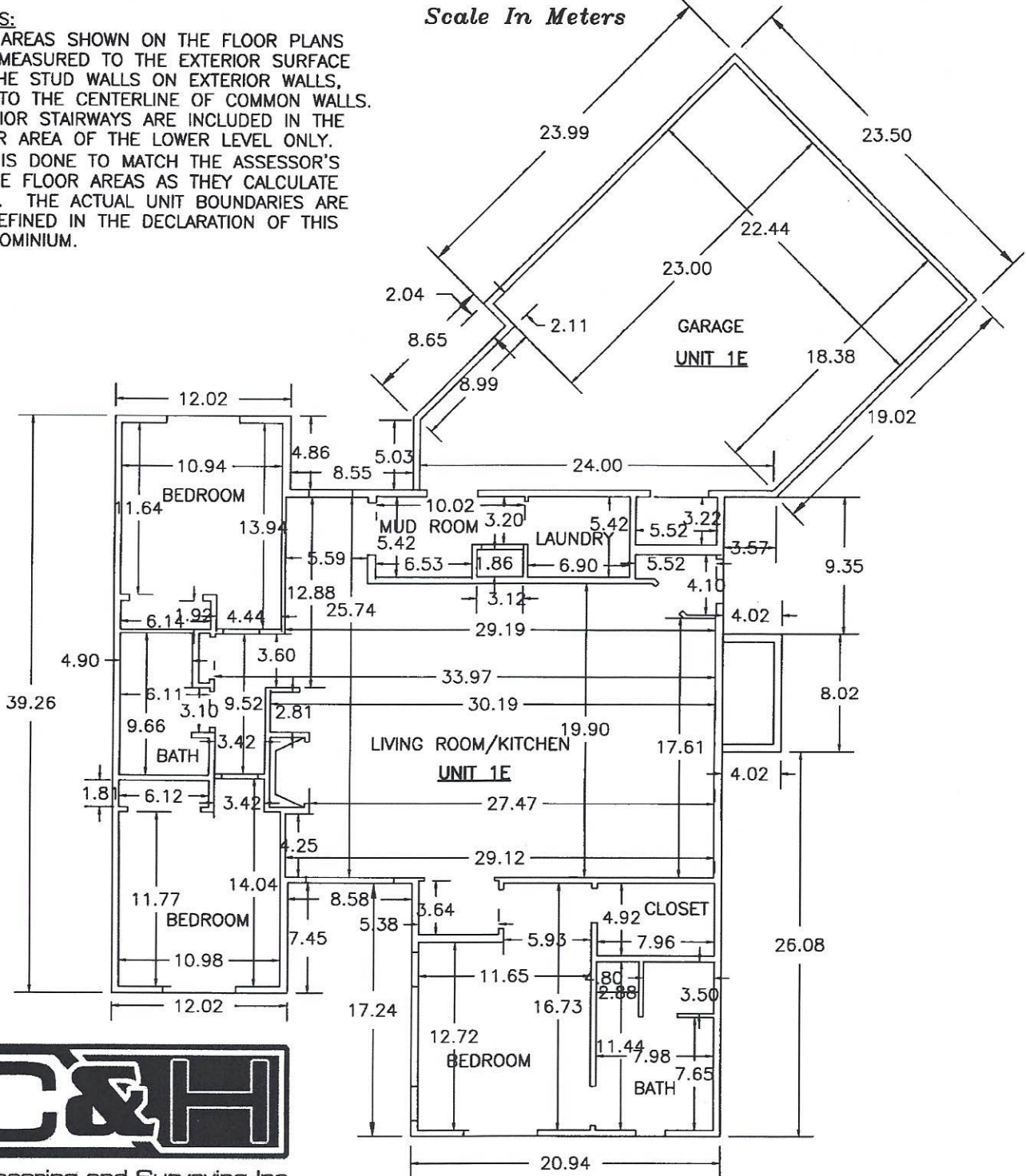

Engineering and Surveying Inc.
 1091 Stoneridge Drive • Bozeman, MT 59718
 Phone (406) 587-1115 • Fax (406) 587-9768
 www.chengineers.com • info@chengineers.com

EXHIBIT E

Percentage of Interest

Phase	Building	Unit Designation	Unit Address	Unit Description	Square Feet	Percentage of Interest
1	1	Unit 1A	91 Croft Farms Road	Typ.	1610 sq. ft.	17.95%
1	1	Unit 1B	93 Croft Farms Road	Bonus room above garage	2069 sq. ft.	23.10%
1	1	Unit 1C	95 Croft Farms Road	Typ.	1610 sq. ft.	17.95%
1	1	Unit 1D	97 Croft Farms Road	Bonus room above garage	2070 sq. ft.	23.10%
1	1	Unit 1E	99 Croft Farms Road	Angled garage	1603 sq. ft.	17.90%
		Total			8962 sq. ft.	100%

Square footage calculation does not include garage square footage.

EXHIBIT F

Certificate of Name

The undersigned being the duly authorized agent of the Department of Revenue of the State of Montana within the County of Gallatin, herewith executes the following certificate relating to the **Croft Farms Condominiums** situated as follows:

Lot 4 of Gallatin River Farm North Major Subdivision Phase 2 – Final Plat, Gallatin County, Montana, according to the official plat thereof on file and of record in the office of the County Clerk and Recorder, Gallatin County, Montana [Plat Reference J-504].

1) That the name the **Croft Farms Condominiums** is not the same as, similar to or pronounced the same as a word in the name of any other property or subdivision within Gallatin County, except for the word “Condominium”, and

2) All taxes and assessments due and payable for the said **Croft Farms Condominiums** have been paid to date.

Dated:

9-18-17

By:

Michelle Shell

Title:

PVS III

Tax ID:

RFF63512

**Exemption Approval from the Belgrade Planning Department
Attached**



CERTIFICATE OF EXEMPTION FROM SUBDIVISION REVIEW

I, Jason Karp, Planning Director for the City of Belgrade, do hereby certify that the Declaration for the Croft Farms Condominiums, submitted October 21, 2017, by Mindy Cummings of Griffith & Cummings PLLC, pursuant to Title 70, Chapter 23, Montana Code Annotated, is exempt from review under the Montana Subdivision and Platting Act pursuant to Section 76-3-203 (1) MCA.

The condominiums are to be located on the following described real property:

Lot 4 of Gallatin River Farm North Major Subdivision Phase 2 – Final Plat, Gallatin County, Montana, according to the official plat thereof on file and of record in the office of the County Clerk and Recorder, Gallatin County, Montana [Plat Reference J-504].

The Declaration is exempt because the condominiums are being constructed in a subdivision that expressly contemplated the construction of condominiums and parkland dedication requirements were addressed at the time of subdivision review.

DATED this 2nd Day of November 2017.

BELGRADE CITY-COUNTY PLANNING OFFICE



Jason Karp, Planning Director

